

## QUAD FLAP MANEUVER

Some examples of extended flight possibilities using the quad flap option and a computer radio are illustrated below.

### Short Takeoff

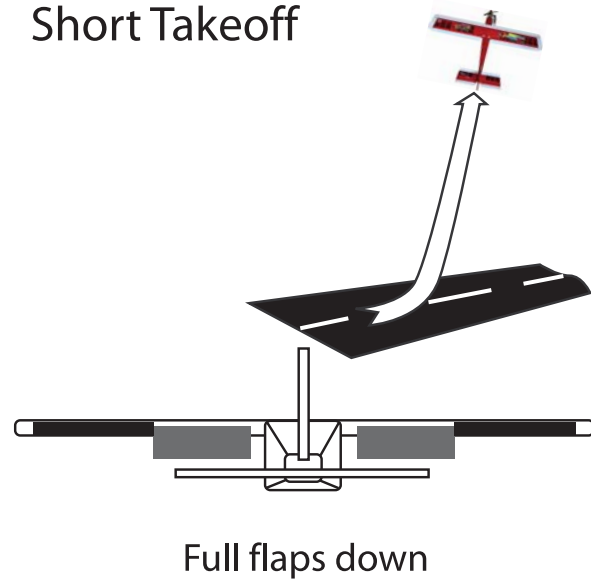

### Dive Brakes to Landing

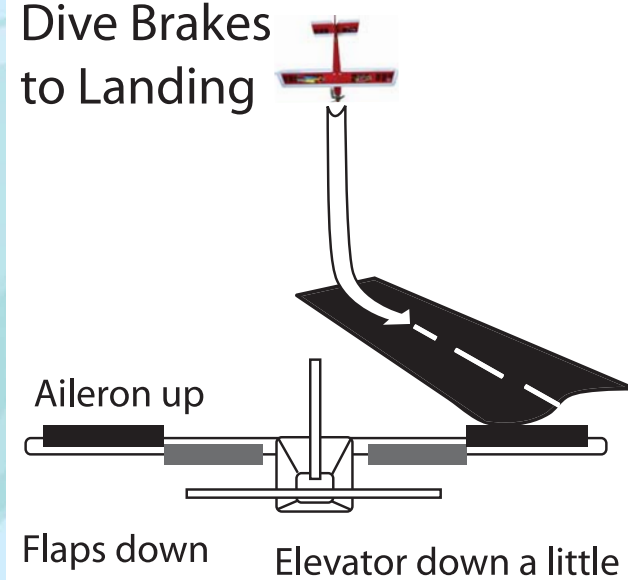

### Rapid Rolls

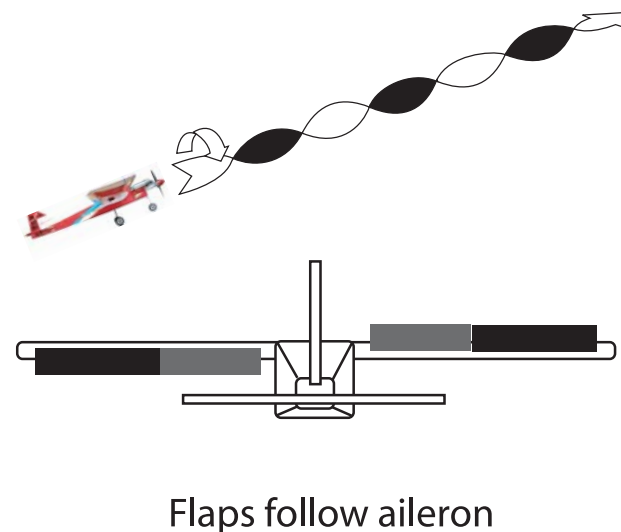

### Tight Loops

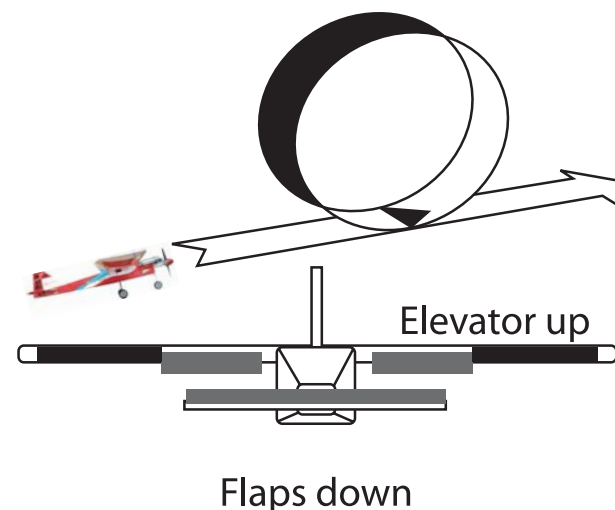

#### Parts for this VMAR Model

In the event that you require replacement parts for your VMAR - XTREME STICK 40-52 ARF, you can order parts from your retailer or from the VMAR On - line store at: [www.richmondrc.com/support.htm](http://www.richmondrc.com/support.htm).

For aftermarket parts and other information related to this model see the VMAR On - Line store at [www.richmondrc.com/support.htm](http://www.richmondrc.com/support.htm)

VMAR, POLYCOTE, V-COTE 2-3DS, VMAX and VCA are Trademarks of VMAR Manufacturing Inc. and appointed agents worldwide  
Copyright VMAR Manufacturing Inc. 20050124



## ASSEMBLY & OPERATIONS MANUAL

Please review this manual thoroughly before assembling or operating this model.

### Proceeding with assembly and use of this product indicates Agreement With & Acceptance of the following Liability Disclaimer.

Model airplanes, model engines, model engine fuel, propellers and related accessories, tools and equipment can be hazardous if improperly used. Be cautious and follow all safety recommendations when using your VMAR model airplane. Keep hands, tools, clothing and all foreign objects well clear of engines when they are operating. Take particular care to safeguard and protect your eyes and fingers and the eyes and fingers of other persons who may be nearby. Use only a good quality propeller that has no cracks or flaws. Stay clear of the propeller and stay clear of the plane of rotation defined by the propeller. The Manufacturer, Distributor, Retailer and/or other

suppliers of this product expressly disclaim any warranties or representations, either expressed or implied, including but not limited to implied warranties of fitness for the purposes of achieving and sustaining remotely controlled flight. In no event will the Manufacturer, Distributor, Retailer and/or other suppliers of this product have any obligation arising from contract or tort, or for loss of revenue or profit, or for indirect, special, incidental, consequential or other damages arising from the use of this product. In purchasing and/or using this product, the user accepts all responsibility for its use and accepts all liability associated with such use.

### CAUTION

A Remote Control Model Aircraft is not a toy. It is a flying model that functions much like a full size airplane. If you do not assemble and operate this product properly you can cause injury to yourself and others and damage property. **DO NOT FLY** this model if you are not qualified. You are entirely responsible for the mechanical,

aeronautical and electrical integrity of this model and its structure, control surfaces, hinges, linkages, covering, engine, radio, wiring, battery and all other components. Check all components before and after each flight.

**Don't fly until it's right!**



**POLYCOTE™ ECS**  
ENHANCED COVERING SYSTEM

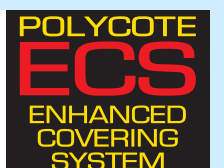

The Graphics and Detailing are inside the POLYCOTE ECS!



# STAGE 1

## WING ASSEMBLY - JOINING THE WING HALVES

### Parts needed

- Right and left wing panels
- Roll of wing joiner tape
- Wing joiner (also called dihedral brace)
- Two short dowel guides

### Tools and Adhesives needed

- 30 minute epoxy
- Epoxy brush or stir sticks
- Disposable mixing dish for the epoxy
- Sandpaper (Coarse 240 grit recommended)
- Low tack masking tape
- Pencil
- Knife
- Ruler
- Paper towels.

**Step 1.1** Locate the wing joiner (also called Dihedral brace). Using a ruler, determine the center of the wing joiner and mark it with a pencil as illustrated in 1A. Also mark a center line on each of the dowel guides.

**Step 1.2** Trial fit the wing joiner into the wing panels. It should insert smoothly up to the center line as illustrated in 1B. Now slide the other wing panel onto the wing joiner until the wing panels meet. If the fit is overly tight, sand the wing joiner slightly and try again. Mark the joiner to indicate which way is UP as illustrated in 1A.

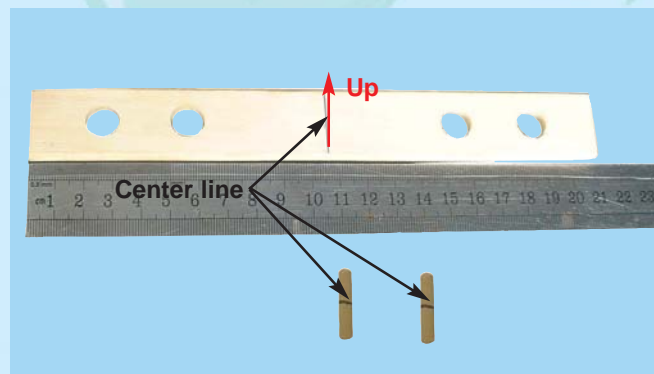

1A - Preparation of wing joiner and dowel guides.

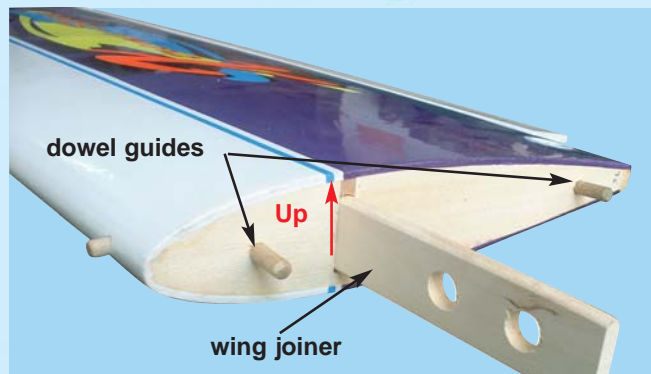

1B - Trial fit the wing joiner and dowel guides

**Step 1.3** Insert the dowel guides into one of the wing panels all the way to the center lines. Apply CA glue to secure the dowels into their places as illustrated in 1B and 1C. Do not apply CA glue to the wing joiner.

**Step 1.4** Apply plenty of 30 minute epoxy to one end of the wing joiner, using a stir stick or epoxy brush. Carefully insert the joiner into the first wing panel as illustrated in 1D, 1E and 1F, then wipe off the excess epoxy that squeezes out of the joint with a cloth or tissue. Repeat this process several times to ensure that the wing joiner and cavity are well coated in epoxy. When the wing joiner & cavity are well coated with 30 minute epoxy, insert the joiner to the center line, wipe away any excess epoxy and let dry. (Note: Do not use 5 minute epoxy or CA to join the wings)

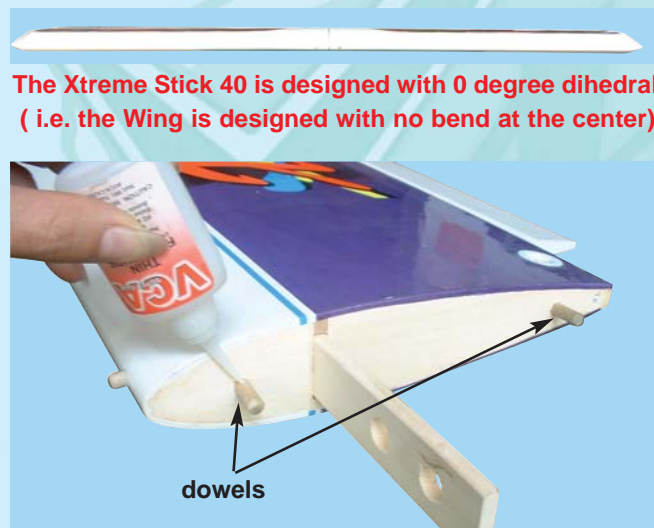

1C - Apply CA glue to secure dowels into their places

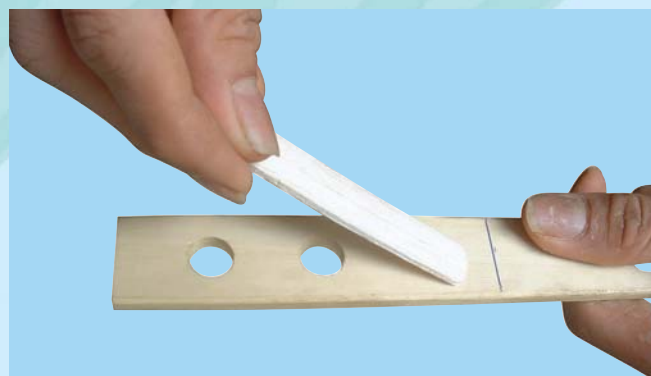

1D - Apply plenty of 30 minute epoxy to the wing joiner.

The Xtreme Stick 40 is designed with 0 degree dihedral ( i.e. the Wing is designed with no bend at the center)

### CONTROL SURFACE THROW SPECIFICATIONS:

The throws are measured at the widest part of the control surface. Adjust the position of the pushrods at the control and/or servo horns to control the amount of throw. You may

also use ATV's if your radio has them but the mechanical linkages should still be set so that the ATV's are near 100% for best servo resolution.

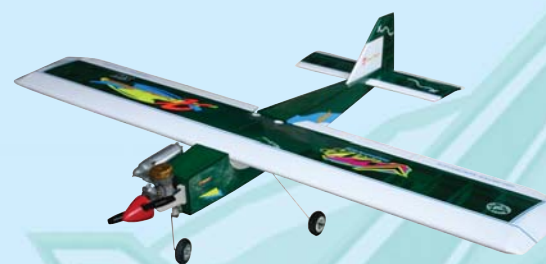

	Low rate		High rate
ELEVATOR	1/3 " (8mm)	up	After first flight tests set the High Rates as aggressive as you wish
AILERON	1/3 " (8mm)	down	
	1/4" (6 mm)	up	
	1/4" (6 mm)	down	
RUDDER	5/8 " (16 mm)	right	
	5/8 " (16 mm)	left	

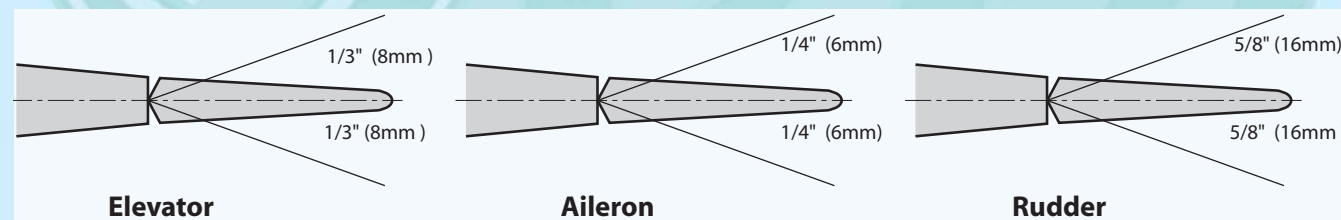

# STAGE 34

## QUAD FLAP CONFIGURATION

The quad flap option and a computer radio allows your Xtreme Stick 40 to perform complex flight maneuvers that are just not possible using ailerons only. With quad flaps and a computer radio different wing con-

figurations can be programmed to extend the flight performance envelope. The procedures for activating the quad flap option are summarized below.

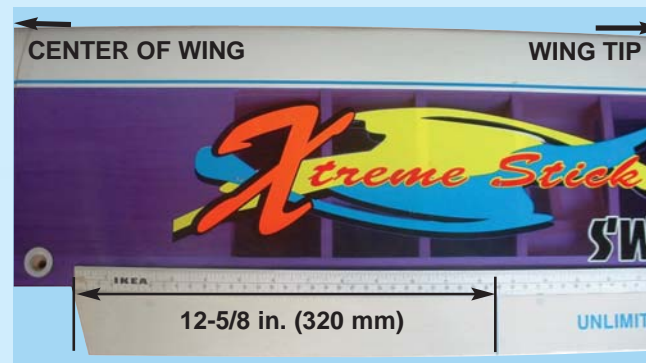

34A - Using a ruler and pen, measure and mark the location where the ailerons will be cut. Measure carefully



35A - Use a hack saw blade or a hobby razor saw to cut through the ailerons at the locations marked

**Step 34.1** Once you have cut the ailerons as illustrated in 34A & 34B, install the two flap servos into the wing, install the flap control horns and install the flap control horns. See Stages 4 - 6 as an example of the general procedure.

**Step 34.2** After installing and connecting the servo control rods, review your computer radio manual for details on connecting the flap servos to your receiver & on how to configure your computer radio to control flaps & ailerons in a coordinated manner



## STAGE 30 INSTALLING THE RECEIVER

**Step 30.1** Consult your radio manual for instructions about hooking up your receiver.

**Step 30.2** Plan where you are going to put the receiver with consideration for routing the antenna safely.

**Step 30.3** Wrap the receiver securely in foam suitable for RC equipment and wrap the foam insulated receiver in a plastic bag or cling wrap.

**Step 30.4** Generally in the absence of specific instructions from the radio manufacturer, it is recommended that the receiver should be placed where it is least likely to have impact during a crash. Keep the battery pack and other heavy loose items ahead of the receiver.

## STAGE 31 CONFIRM RADIO OPERATION

**Step 31.1** Consult your radio manual for instructions about testing and operating your radio system.

**Step 31.2** Pay particular attention to charging your radio system batteries and range testing the system before and after each flight.

**Step 31.3** Check that all controls are working correctly before and after each flight.

## STAGE 32 BALANCING THE AIRCRAFT

**Step 32.1** The CG for your Xtreme Stick is located at 3-1/8" to 3-1/2" (80 - 90 mm) back from the leading edge of the wing when the wing has been attached to the fuselage as per illustration 33A.

**Step 32.2** For the initial flight, the CG should be located at 3 1/8" (80mm) back from the leading edge of the wing when the wing has been attached to the fuselage.

**Step 32.3** The CG is measured with the engine, radio gear and all other components installed but WITH NO FUEL IN THE TANK.

**Step 32.4** Set up the CG as it will be when you fly it BUT WITH NO FUEL IN THE TANK.

**Step 32.5** It is very important to have the CG correct. Flying your model with the CG too far back will likely lead

to loss of control and a crash. If you discover that after you have assembled your model and installed your radio and engine that the CG of your model is incorrect you must bring the CG to the correct location by doing the following BEFORE FLYING :

- Move the battery pack fore or aft.
- Move other components fore or aft.
- Change engine to a lighter or heavier model.
- Add weight to the nose or tail. If adding weight to the nose, try to make it useful by going to a heavier duty engine or adding a spinner with a heavy metal backing plate. As a last resort, add stick on "dead" weight where appropriate.

## STAGE 33 CONFIRM MECHANICAL INTEGRITY

**Step 33.1** Once you have confirmed that the CG is correct, you should do a thorough review of the entire model before your first flight. Check everything twice! Every hook up, every coupling, everything! Do it twice!!

**Step 33.2** Before your first flight, have an experienced flyer review your work. Do not fly your model until it has been checked out by a third party who knows how to fly and how to set up a model aircraft. Do not fly alone. Seek experienced help.

**Step 33.3** Once you have completed your first flight, get in the habit of checking your model over before and after each flight! Don't fly if you find something that is not right!

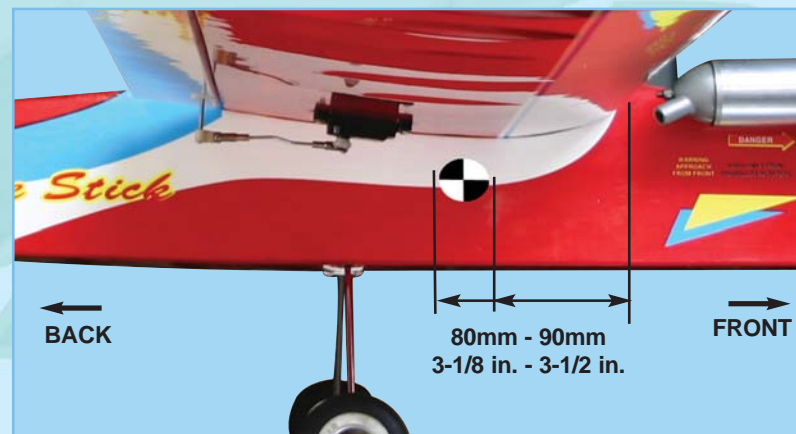

33A - CG location

**WE RECOMMEND MEDIUM GRADE THREAD LOCKER BE APPLIED SPARINGLY TO ALL METAL TO METAL SCREW FASTENERS. DO NOT APPLY TO PLASTIC**

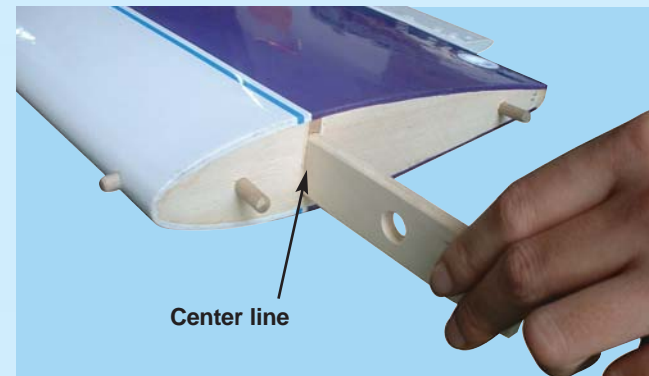

1E - Carefully insert the joiner all the way to the center line



1F - Wipe off the excess epoxy then allow to cure

## STAGE 2 WING ASSEMBLY - JOINING THE WING HALVES (Cont.)

**Step 2.1** When the epoxy has cured in Stage 1, trial fit the second wing panel onto the wing joiner first to ensure that the two panels fit without an excessive gap.

**Step 2.2** Now apply plenty of epoxy to the wing joiner and wing root ribs of both wing panels. Use only 30 minute epoxy to ensure a strong bond and give yourself plenty of working time. As described in the Step 1.4, repeatedly

apply epoxy and insert into the wing joiner cavity, the epoxy should ooze from the joint and the excess should be cleaned off with a rag or tissue before it cures.

**Step 2.3** Use low tack masking tape to hold the two wing panels together until the epoxy cures. See 2C

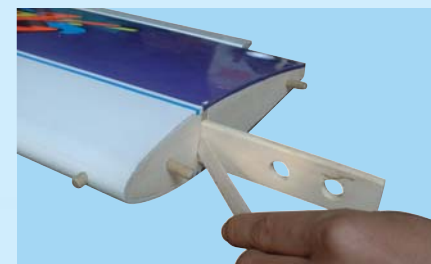

2A - Apply plenty of 30 minute epoxy glue to all surfaces



2B - Align the two wing panels and slowly close the gap until the wing root ends are firmly in contact with each other

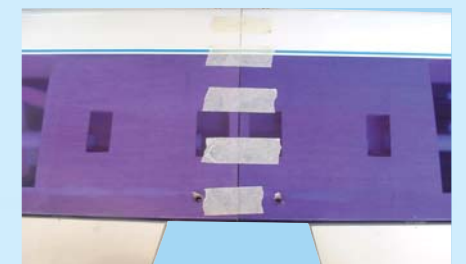

2C - Use low tack masking tape to hold tightly together

## STAGE 3 WING ASSEMBLY - JOINING THE WING HALVES (Cont.)

**Step 3.1** Once the epoxy has cured completely (allow several hours at least), the tape can be carefully removed from the wing panels. Peel the tape back on itself... do not pull upright away from the wing. To seal and finish the joint in the wings, a roll of wing joiner tape has been supplied. Starting on the bottom side of the wing, stick the tape cen-

trally over the joint ensuring that it is pressed down firmly as you work around the wing. Wrap the tape all the way around the wing joint in one piece, starting and finishing at the servo mounting cavity in the bottom of the wing.

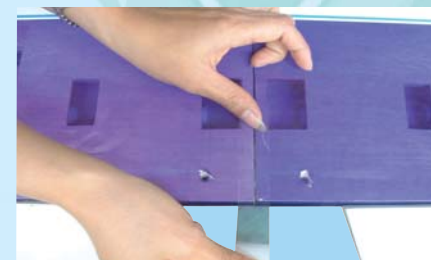

3A- Apply tape over the joint starting here on the bottom at the servo cavity



3B- Continue applying the tape over the top of the wing, pressing down firmly as you go

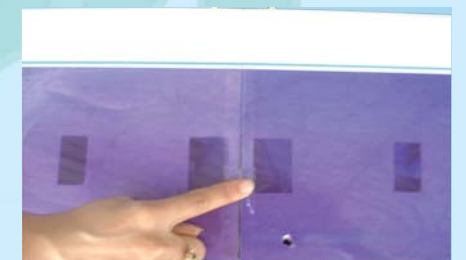

3C- Continue over to the bottom of the wing & along to the servo cable cavity and trim off the excess tape



## STAGE 4 INSTALLING THE AILERON SERVOS INTO THE WING

To install the aileron servos into the wing you will need the following items:

- Servos with servo mounting screws and grommets as supplied with the servos
- Servo control arms as supplied with the servos
- Two aileron control rod assemblies supplied with the kit. The assemblies consist of a metal rod with a clevis screwed onto each end
- Low tack masking tape
- 2 aileron control horn assemblies

**Step 4.1** Locate the four servo cavities in the bottom of the wing. If you going to use quad flaps (four servos) use a sharp hobby knife to trim away the covering over the servo cavities. If you are going to use full span ailerons only (2 servos) remove the covering from the two inboard (closest

to the wing joint) servo cavities only.

**Step 4.2** Trial fit the servos into the appropriate servo mounting cavities. You may have to modify the cavities slightly to provide clearance for the servos and servo wires.

**Step 4.3** Use a hobby knife to modify the cavity as required. Most servos have their output shaft closer to one end than the other. We recommend locating the servo so that the output shaft is as close to the front of the wing as possible.

**Step 4.4** Screw the servo into place with the screws and grommets supplied. It is important to install the grommets and screws correctly. See the manual that came with your radio for instructions about your particular servo grommets.

**Step 4.5** Fasten the screws down according to the servo manufacturers recommended tightness.



4A - Prepare the servo by fitting the rubber grommets & ferrules supplied with your radio



4B - Aileron servo cavities for full span ailerons

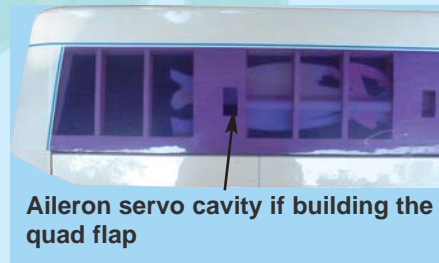

4C - Aileron servo cavity if building the quad flap configuration. (See Stage 34)

## STAGE 5 INSTALLING THE AILERON CONTROL SYSTEM

**Step 5.1** Consult your radio instruction manual and center the aileron servos by plugging them into the aileron channel in the receiver. (Use a Y Harness or computer radio to couple the two servos). Turn on the transmitter and then the receiver.

Center the aileron trim lever on the transmitter. Remove the servo mounting screw and the servo arm from each servo.

**Step 5.2** Mount the servo arm back on the servo so that the arm is parallel with the back edge of the wing. Screw the arm into place with the servo arm mounting screw supplied with the servo.

**Step 5.3** Locate the two aileron control rods in the hardware bag (see 5A). Ensure the clevises are screwed well onto the threaded portion of the rod. Rotate and tug aggressively on the clevises and ensure that they are not loose on the rods.

**Step 5.4** Tape the ailerons into their neutral position so that they are even with the trailing edge of the wing and not pointing either up or down.

**Step 5.5** Ensure that the aileron control horns are screwed onto the threaded aileron torque rods that protrude from the wing and that both control horns are in approximately the same place on their respective torque rods. See 5B

**Step 5.6** Connect the aileron servo control rods between the aileron control horn and the aileron servo arm for each aileron servo.

If necessary use a 5/64 in. (2mm) drill bit to expand the servo arm & control horn holes to fit the clevis screw.

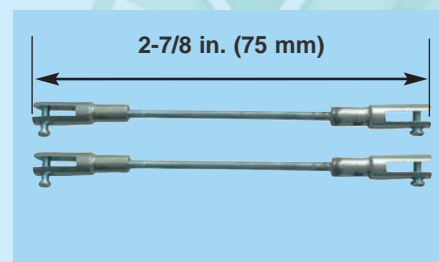

5A - Aileron control rod assembly

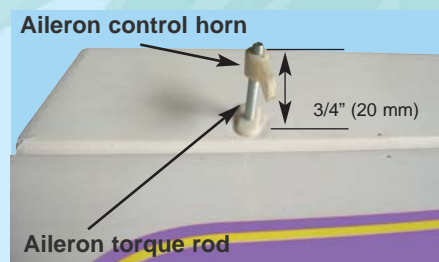

5B - Aileron torque rod with control horn



5C - Aileron servo and control rod installed

## STAGE 27 ADJUST CONTROL SURFACE THROW LIMITS

Adjust the deflection of the control surfaces to match the specifications on page 15. You can reduce the amount of throw by doing either or both of the following:

- From the servo end, move the clevis or EZ connector to a hole in the servo arm that is closer to the servo output shaft.

- From the control horn end, move the horn out further on the threaded bolts. Always confirm that the horn is still thoroughly engaged with the threaded bolt after you have adjusted it.

## STAGE 28 FINAL RC SET-UP

Before starting the final set-up of the model, switch on the radio and ensure that all trims are in their neutral positions. Check that the ailerons, elevator and rudder are centered. If any adjustments are needed, do these by uncoupling the relevant clevis and turning it clockwise to shorten the linkage or counter-clockwise to lengthen it. Only when each control surface has been centered mechanically in this way should you begin adjusting the surface movement (or throw)

Now confirm that the control surfaces are moving in the correct direction. Use the servo reversing switches on your transmitter to reverse the direction of a servo if necessary. The most popular transmitter mode (with the throttle on the left, with ailerons and elevator on the right) is shown here.

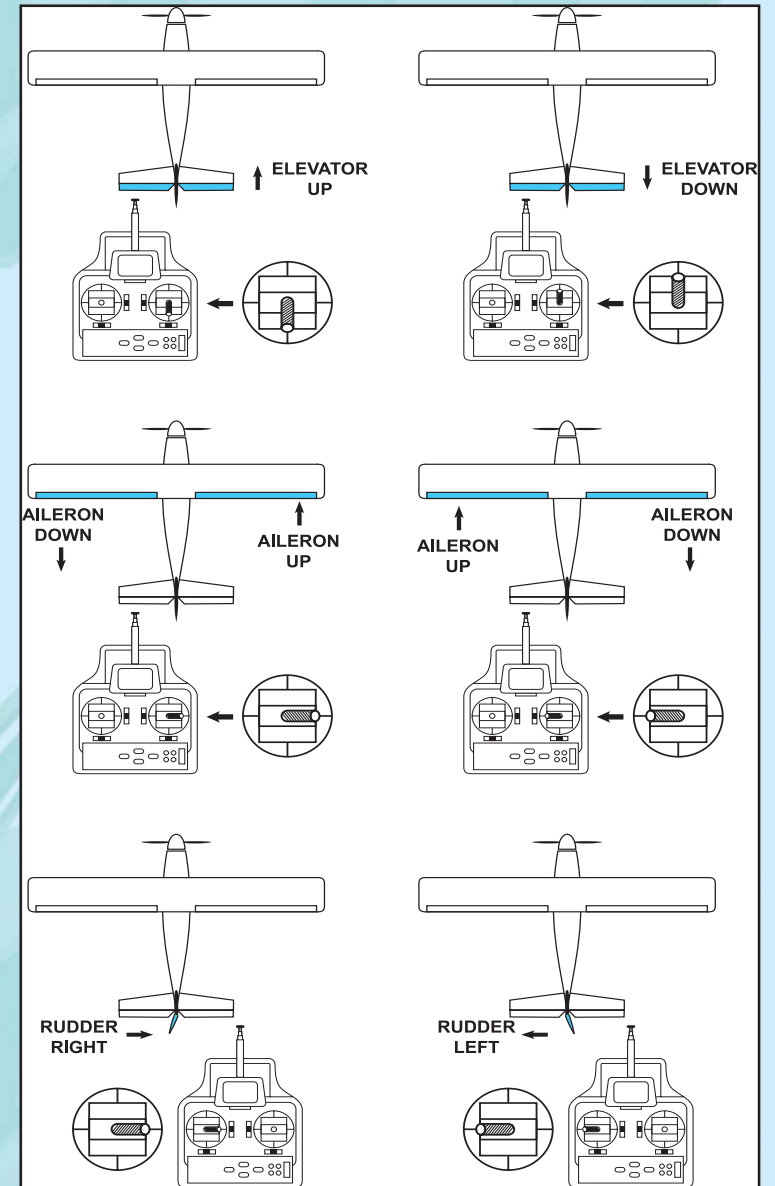

## STAGE 29 INSTALLING THE RECEIVER BATTERY

**Step 29.1** Consult your radio manual for instructions about hooking up your receiver battery, receiver and switch harness.

**Step 29.2** Wrap the battery pack securely in foam suitable for RC equipment and wrap the foam insulated pack in a plastic bag or cling wrap. Position the battery pack under the fuel tank or nearby.

**Step 29.3** Thread the battery pack connector back through from beneath the fuel tank to the radio compartment by passing the battery connector through an opening beside or beneath the fuel tank.

**Step 29.4** Connect the battery connector to your radio system according to the radio manual.



## STAGE 23

### CONNECTING THE PUSHRODS TO THE THROTTLE, RUDDER AND ELEVATOR SERVOS

Consult illustrations 22C & 23A-B showing how the throttle, rudder and elevator servos are positioned and connected to the pushrods.

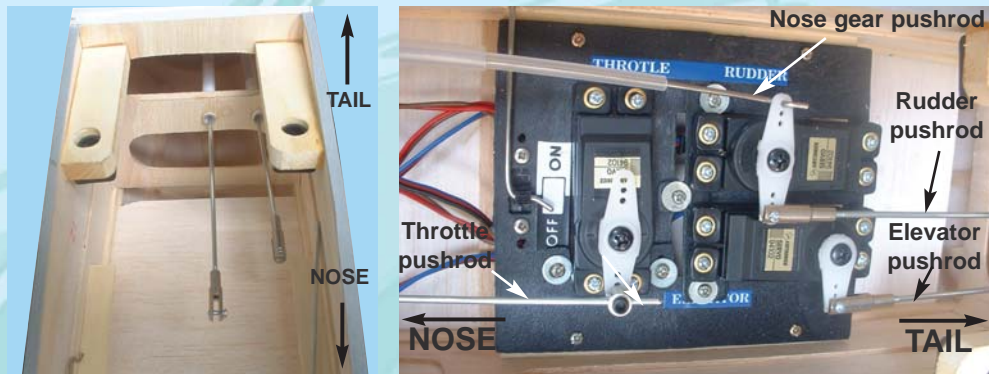

23A - Pre-installed elevator, throttle and rudder pushrod

23B - Center the servos, control surfaces & throttle (carb) then connect the control rods to the servos

## STAGE 24

### CONNECTING THE PUSHROD TO THE ELEVATOR

Connect the elevator servo to the receiver and turn on your transmitter. Confirm that the neutral positions of the

elevator servo are sustained as per illustration 23B

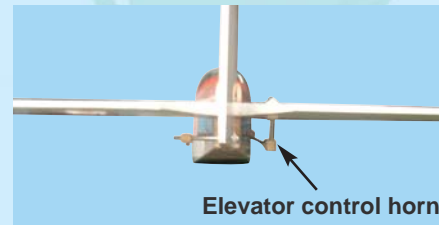

24A - Elevator control horn shown in position

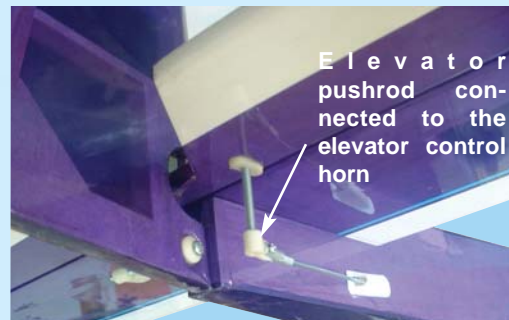

24B - Align the elevator with the plane of the horizontal stabilizer. Rotate the clevis to adjust the effective length of the control rod. Connect the clevis to the control horn. Ensure the clevis is securely attached to the control rod and the control horn

## STAGE 25

### CONNECTING THE PUSHROD TO THE RUDDER

Connect the rudder servo to the receiver & turn on your transmitter. Confirm that the neutral position of rudder servo is sustained as per illustration 23C. Align the rudder with the plane of the vertical stabilizer. Rotate the clevis to adjust the effective length of the control rod. Connect the clevis to the control horn. Ensure the clevis is securely attached to the control rod and the control horn.



25A - The rudder pushrod connected to the rudder control horn

## STAGE 26

### ADJUSTING THE THROTTLE CONTROL ROD

With the throttle control arm clevis connected to the engine throttle arm, move the throttle arm to roughly half throttle. Look into the throat of the engine carburetor as you rotate the throttle arm and select a position where the throttle opening is about half what it is when fully open.

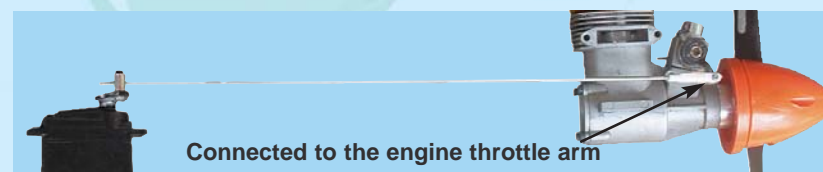

26A - Throttle control rod connected to the engine throttle arm and to the throttle servo arm

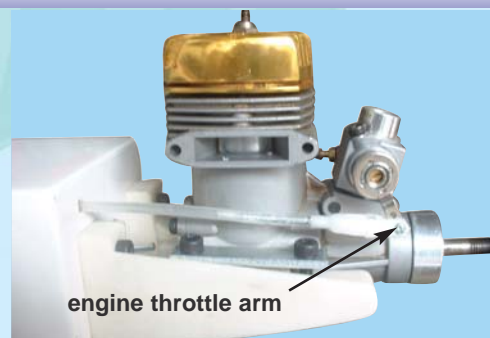

26B - Throttle control rod connected to the engine throttle arm

**Step 5.7** Connect the aileron servo control rods to the aileron control horns as shown in 5C.

**Step 5.8** Carefully remove the masking tape holding the ailerons.

**Step 5.9** Turn on your radio and activate the ailerons, using the aileron stick and ensure that a smooth full motion can be achieved.

**Step 5.10** With the wing top side up and viewed from the back, ensure that moving the transmitter aileron stick to the left raises the left aileron and lowers the right aileron.

Movement of the stick to the left will roll the aircraft to the left. (counterclockwise roll of the wing when viewed from the back).

**Step 5.11** With the wing top side up and viewed from the back, ensure that moving the transmitter aileron stick to the right raises the right aileron and lowers the left aileron. Movement of the stick to the right will roll the aircraft to the right (clockwise roll of the wing when viewed from the back).

## STAGE 6

### FITTING THE HORIZONTAL AND VERTICAL STABILIZERS

To install the stabilizers you will need:

- Fuselage
- Vertical stabilizer with pre-installed rudder
- Horizontal stabilizer with pre-installed elevator

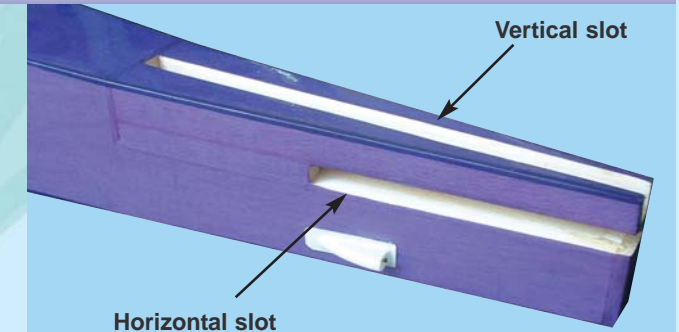

6A - The fuselage slots for the vertical & horizontal stabilizers



6B - Horizontal stabilizer with pre-installed elevator

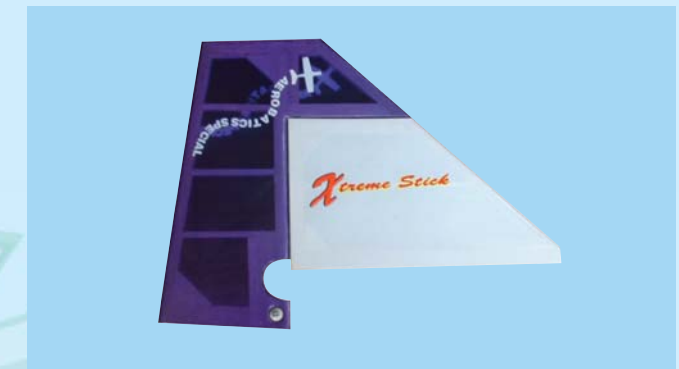

6C - Vertical stabilizer with pre-installed rudder

## STAGE 7

### ALIGNMENT OF HORIZONTAL STABILIZER

Check the fit of the horizontal stabilizer in its slot. Make sure the tail is square and centered to the fuselage by taking measurements as shown in pictures 7A, 7B and 7C.

**DO NOT GLUE ANYTHING YET**

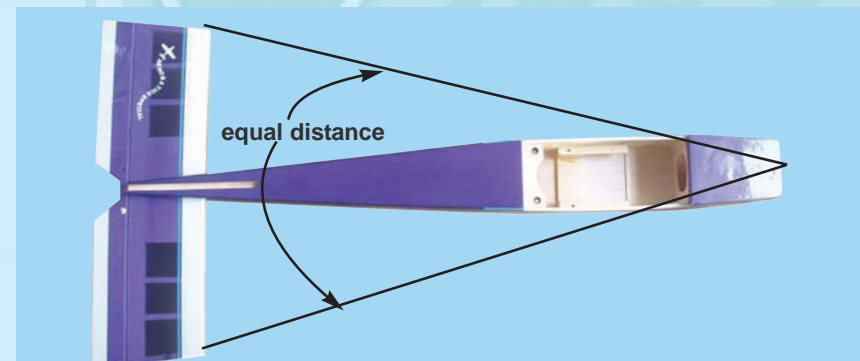

7B - Alignment of horizontal stabilizer top view.

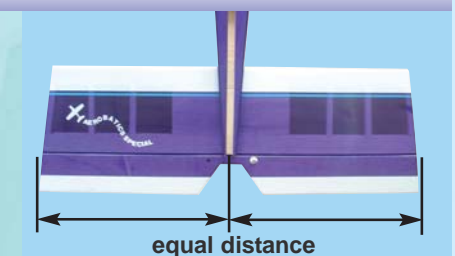

7A - Trial fit the horizontal stabilizer in its slot

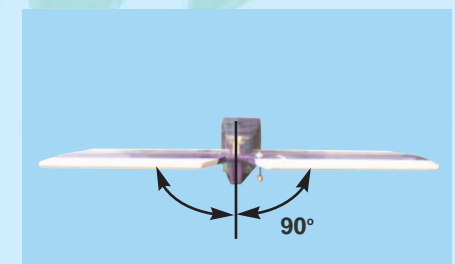

7C - Alignment back view



## STAGE 8 INSTALLING THE HORIZONTAL STABILIZER

With the horizontal stabilizer aligned correctly, mark the shape of the fuselage on the top & bottom of the horizontal stabilizer using a water soluble non-permanent felt-tip pen as shown here

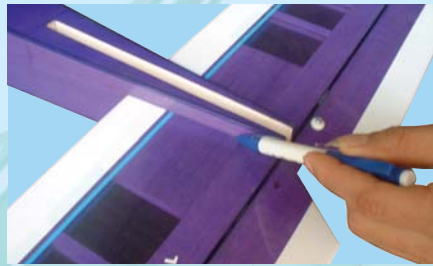

8A - Mark the top of the horizontal stabilizer...



8B - ...and the bottom stabilizer...

## STAGE 9 INSTALLING THE HORIZONTAL STABILIZER (Cont.)

Now remove the horizontal stabilizer & using a sharp knife & a ruler CAREFULLY cut 1/8" (3 mm) inside the marked lines & remove the covering on the top & bottom of the horizontal stabilizer as illustrated. Make sure you **only cut the film & not the wood**, otherwise the horizontal stabilizer will be severely weakened & fail (In some markets the covering will have been removed by the factory).

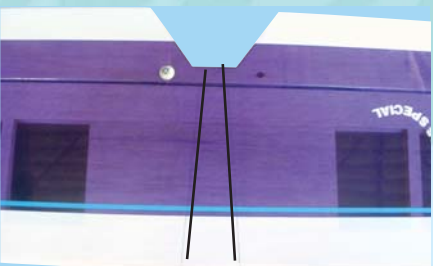

9A - Marked lines on horizontal stabilizer. **IN SOME MARKETS THE COVERING WILL HAVE BEEN REMOVED AT THE FACTORY**



9B - Cutting inside the lines. **DO NOT CUT THE WOOD**

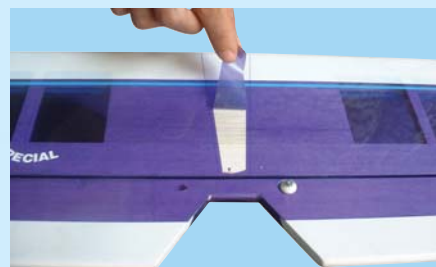

9C - Remove the covering from top surface



9D - Exactly the same underneath



9E - Clean off the pen lines.

## STAGE 10 THE HORIZONTAL STABILIZER (Cont.)

**Step 10.1** Now apply sufficient epoxy to the top and bottom of the horizontal stabilizer and horizontal slot. Use 30 minute epoxy to ensure a strong bond and give yourself plenty of working time. See 10A & 10B

**Step 10.2** Insert the horizontal stabilizer in its slot in the fuselage and re-check the alignment as in Stage 7. See 10C and 7A, 7B & 7C

**Step 10.3** Excess epoxy should be cleaned off with a rag or tissue before it cures. See 10D



10A - Apply plenty of epoxy

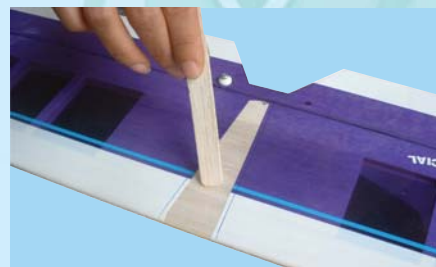

10B - Apply plenty of epoxy



10C - Slide the horizontal stabilizer in place



10D - Wipe off excess epoxy

## STAGE 20 INSTALL THE PROPELLER AND THE SPINNER

**Step 20.1** Consult your engine manual and select a suitable propeller.

**Step 20.2** Install the thrust washer, the spinner backing plate, the propeller, the prop washer, and the prop nut. Ensure that they are all firmly attached.

**Step 20.3** Trial fit the spinner cone and spinner cone retaining screws. If necessary enlarge the cutouts in the spinner cone to allow adequate clearance for the propeller. The spinner should not touch the edges of the propeller.

**Step 20.4** Double check that the spinner cone retaining screws are firmly attached



20A - The spinner and propeller attached to the engine

## STAGE 21 FITTING THE ELEVATOR & RUDDER CONTROL HORNS

The elevator control horn is installed through the elevator and protrudes from the bottom of the elevator as shown in 21B and 21C. Pierce the covering over the pre-drilled hole and install the control horn as shown.



21 - Control horn assembly

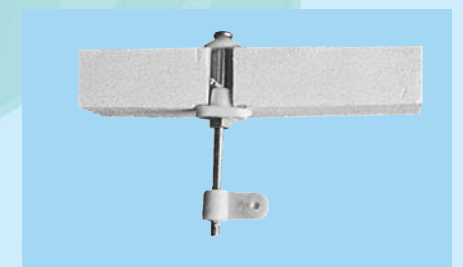

21B - Typical control horn mounted to a control surface

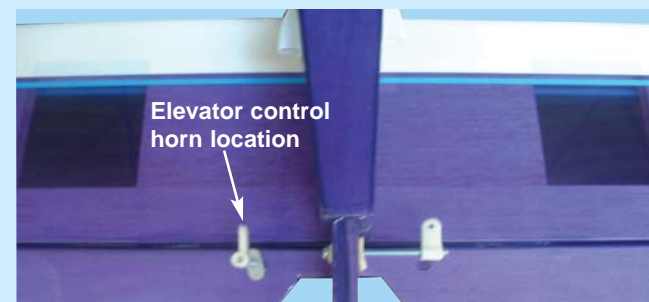

21C - Elevator control horn location

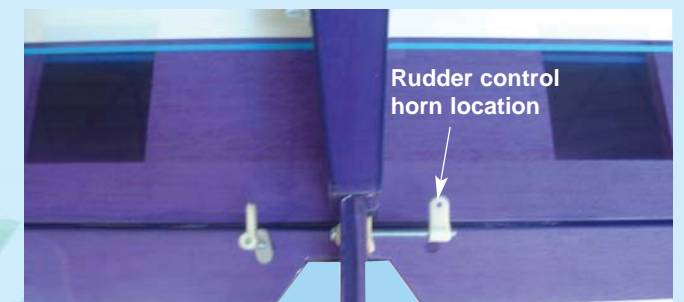

21D - Rudder control horn location

## STAGE 22 INSTALLING THE SERVOS

Install the rubber servo grommets & brass ferrules supplied with your radio equipment. The three servos that control the elevator, rudder and throttle are to be installed in the servo tray mounted in the fuselage. Remove the servo tray from the fuselage, and install the servos in the servo tray as shown in 22B

22A - Universal servo tray

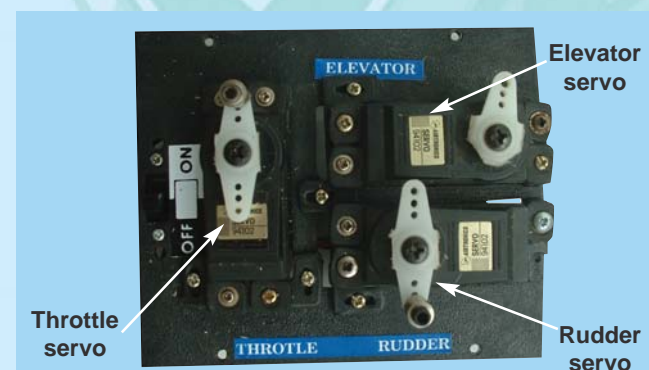
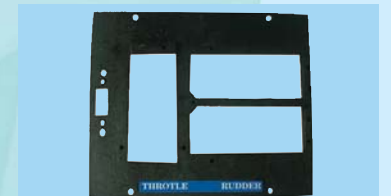

22B - Note the orientation and positions of the three servos in the servo tray



22C - Throttle, rudder and elevator servos connected to their push rods as referenced left to right



## STAGE 17 INSTALL ENGINE

Engines vary quite a bit in sizes, styles and brands but most have mounting lugs, a carburetor with a throttle (speed) control arm, a prop washer, a prop nut and a muffler.

The procedure we describe here assumes that you are mounting a 2-stroke engine that has a side exhaust on the right (when viewed from behind looking forward) and a throttle control arm on the right.

Connect to the fuel line

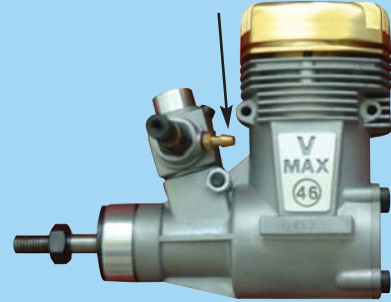

17A - VMAX 46PRO 2 cycle engine recommended

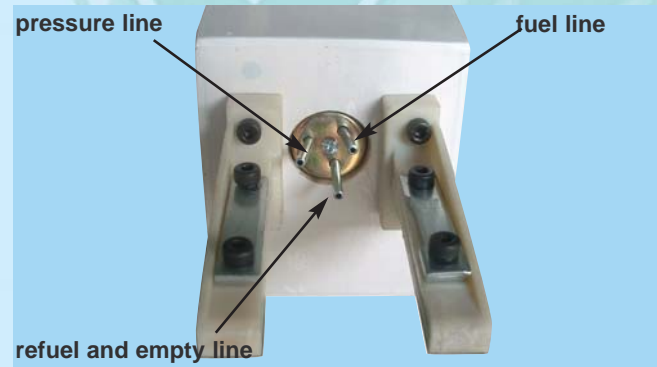

17B - Use a 4mm socket ball wrench or Allen Key to remove the 4 black machine screws that secure the clamping plates to the engine mount that engine mount that has been pre-installed into your Xtreme Stick

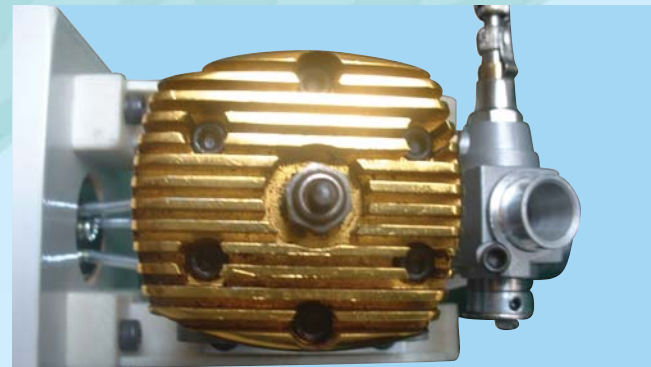

17C - Remove the muffler, position the engine on the engine mount and confirm that the fuel tank metal tubes clear the back of the engine. Trial fit the engine temporarily into place. Tighten the screws only enough to tack the engine into place for now

## STAGE 18 CONNECTING THE THROTTLE CONTROL ROD TO THE ENGINE.

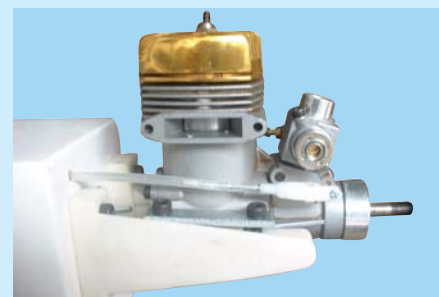

18A - Clevis attached to engine throttle arm

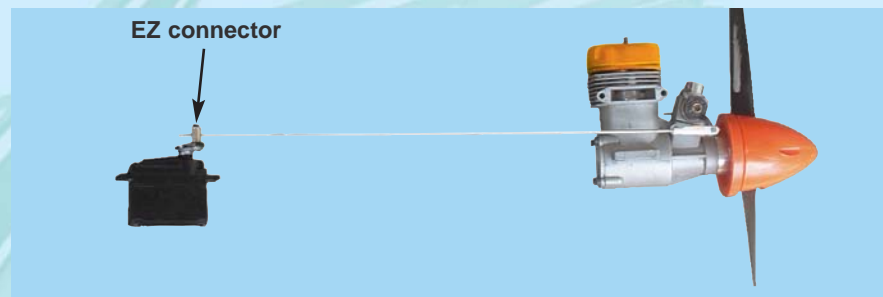

18B - Throttle control rod connected to the engine throttle arm and to the throttle servo arm

## STAGE 19 CONNECTING THE FUEL & PRESSURE LINES

**Step 19.1** Install the muffler then connect the fuel tubing from the tank metal pressure line to the muffler.

**Step 19.2** Connect the fuel tubing from the tank metal fuel line to the carburetor.

**Step 19.3** Double check that you have the metal fuel line from the tank connected to the carburetor and that the metal pressure line from the tank is connected to the muffler.

**Step 19.4** Connect about 4 in. (10cm) of medium ID silicone fuel tubing to the tank metal refuel line. Plug the open end of the tubing with a 3mm machine screw after fueling to ensure the tank is pressurized.



19A - Fuel line connected to the carburetor and pressure line connected to the muffler

## STAGE 11 FITTING THE VERTICAL STABILIZER

**Step 11.1** Check the fit of the vertical stabilizer in its slot. Make sure that it is square to the horizontal stabilizer and fuselage. See 11A and 12C

**Step 11.2** Mark the shape of the fuselage on the left & right sides of the vertical stabilizer using a felt-tip pen. Step 11B

**Step 11.3** Now remove the vertical stabilizer, using a sharp knife & ruler, CAREFULLY cut just 1/8" (3mm) inside the marked lines (see 11C) and remove the covering on both sides of the fin (see 11D), just as you did with the horizontal stabilizer, making sure you only press hard enough to cut the covering, not the vertical stabilizer.

**IN SOME MARKETS THE COVERING WILL HAVE BEEN REMOVED BY THE FACTORY**



11A - Trial fit the vertical stabilizer into fuselage slot.



11B - Mark both sides of the vertical stabilizer



11C - Carefully cut through the covering. **DO NOT CUT THE WOOD**



11D - Remove covering from both sides

## STAGE 12 FITTING THE VERTICAL STABILIZER (Cont.)

**Step 12.1** Now apply sufficient epoxy to both sides & the bottom of the vertical stabilizer as illustrated in 12A. Use 30 minute epoxy to ensure a strong bond and give yourself plenty of working time.

**Step 12.2** Insert the vertical stabilizer in its slot in the fuselage and re-check the alignment. Excess adhesive should be cleaned off with a rag or tissue before it cures.



12A - Apply plenty of epoxy



12B - Slide the stab into place & remove excess epoxy

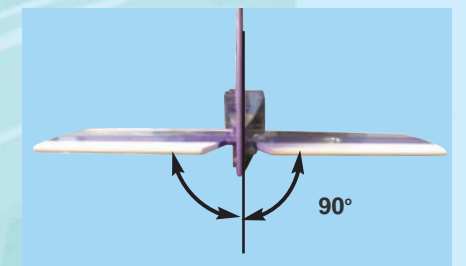

12C - 90 degree angle between the horizontal and vertical stabilizers

## STAGE 13 INSTALLING THE LANDING GEAR

The Xtreme Stick SW has a tricycle gear configuration (trike gear) using a steerable nose wheel and main landing gear. Trike gear makes it much easier to steer your model on the ground and to control it during take off.





## STAGE 14 FITTING THE MAIN LANDING GEAR

Identify the main landing gear components shown below

- 2 pre-bent main landing gear wires
- 2 main wheels 2-7/16" ( 60mm)
- 4 sheet metal screws and 2 straps
- 4 wheel collars

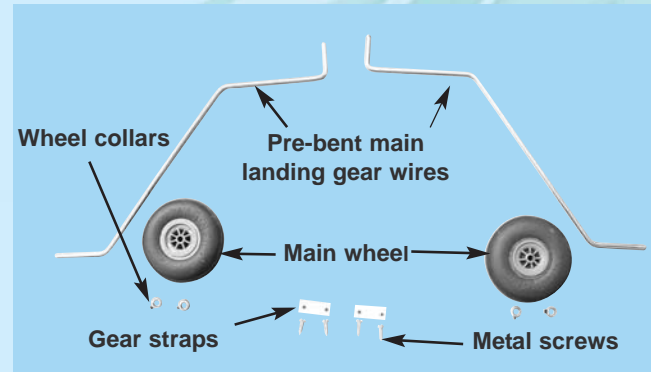

14A - Main landing gear components

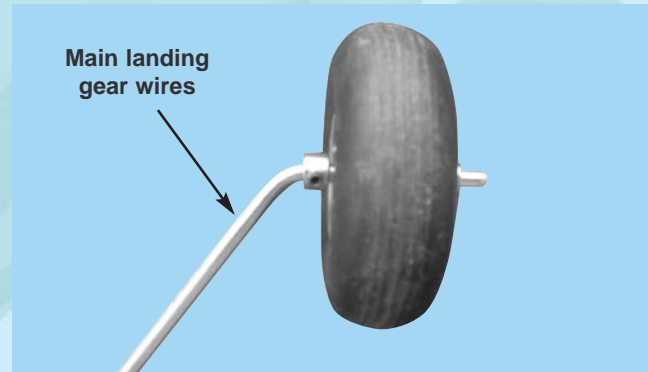

14B - Installation of collars and wheel to the pre-bent main landing gear wire

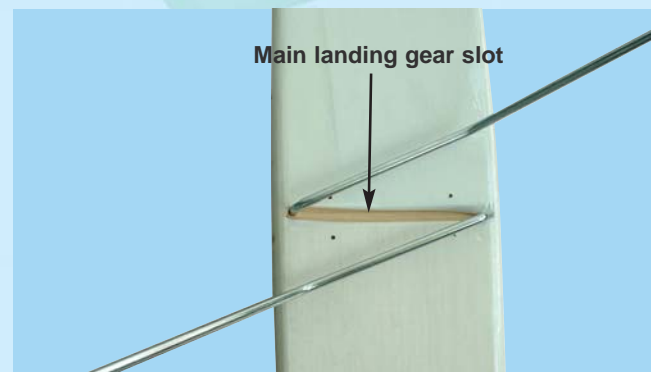

14C - Turn over the fuselage to locate the pre-drilled main landing gear mounting holes

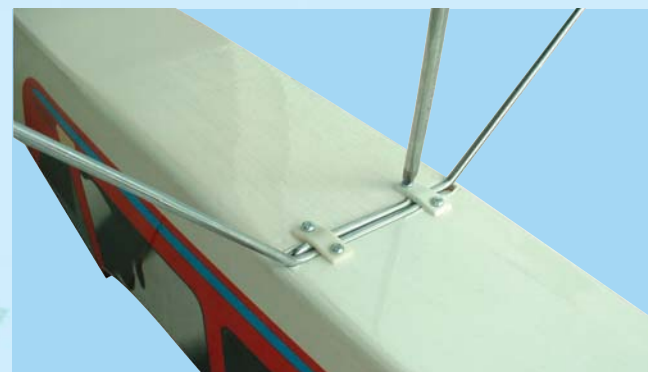

14D - Use 4 sheet metal screws and 2 straps to mount the main landing gear onto the fuselage

## STAGE 15 INSTALLING THE NOSE GEAR

Identify the nose gear components per illustration 15A:

- 1 pre-bent nose gear wire
- 1 steering arm
- 2 wheel collars
- 1 wheel 2-7/16" ( 60mm)



15A - Nose gear components

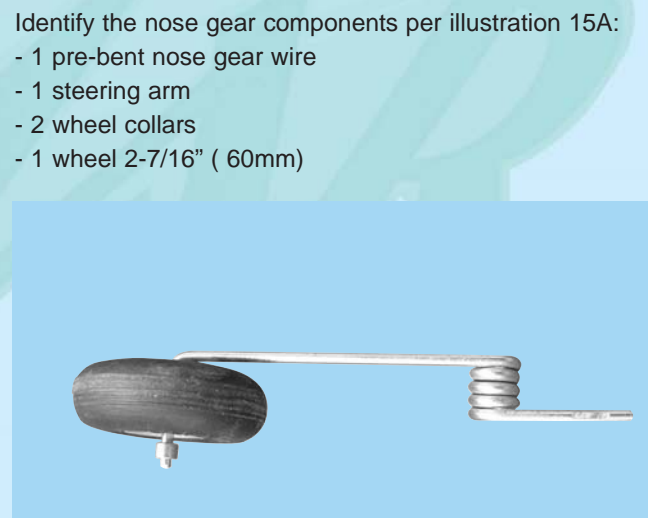

15B - Install the nose wheel and collars and then follow the sequence illustrated in 15C, 15D and 15E to install the nose gear as shown in 15F



15C - Insert the end of the pre-installed Z-bend wire into the hole in the steering arm



15D - Place the steering arm into the slot in the nylon nose gear bearing



15E - Insert the nose gear into the bearing, passing through the steering arm. Secure the steering arm to the nose gear by tightening the set screw onto the flat spot on the nose gear wire



15F - Typical nose gear installation when complete

## STAGE 16 FITTING THE FUEL TANK

To assemble the fuel tank you will need the following items:

- The fuel tank and fuel stopper assembly (supplied)
- 2 clunky (supplied)
- About 10 in. (25.4 cm) of medium ID silicone fuel line (DUB-197 or DUB-222 or similar)

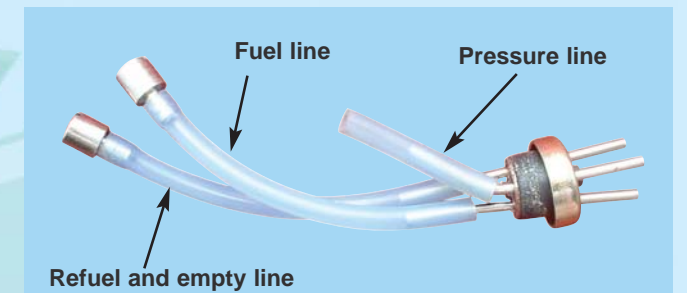

16A - Use 2 in. (50 mm) for the pressure line and 4 in. (100 mm) for the refuel line

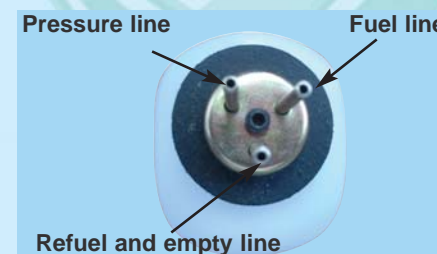

16B - Fuel tank and stopper assembly (front view)

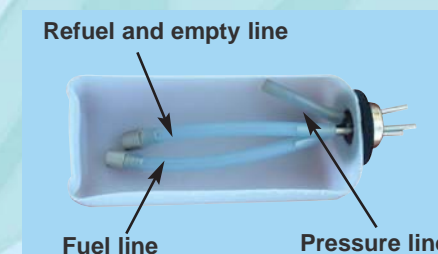

16C - Illustration of fuel line positioning inside cutaway of the tank

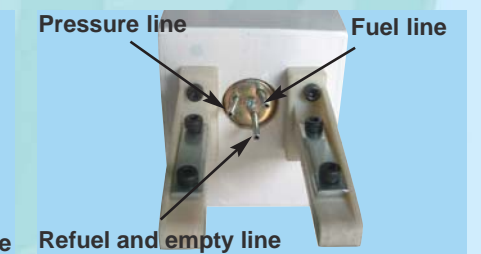

16D - Fuel tank installed into the fuselage

After tank assembly, protect tubes from contamination during installation. Apply silicone on both sides of black foam donut like gasket & around neck. Install tank into the fuselage with the end of the pressure line inside the tank touching or nearly touching the top of the tank as the tank is oriented in the fuselage.

Press tank with sealant bead firmly against back of firewall & secure while sealant cures. Seal around neck from front to prevent oil seepage into fuselage.. Support & surround tank in compartment with sponge foam.