

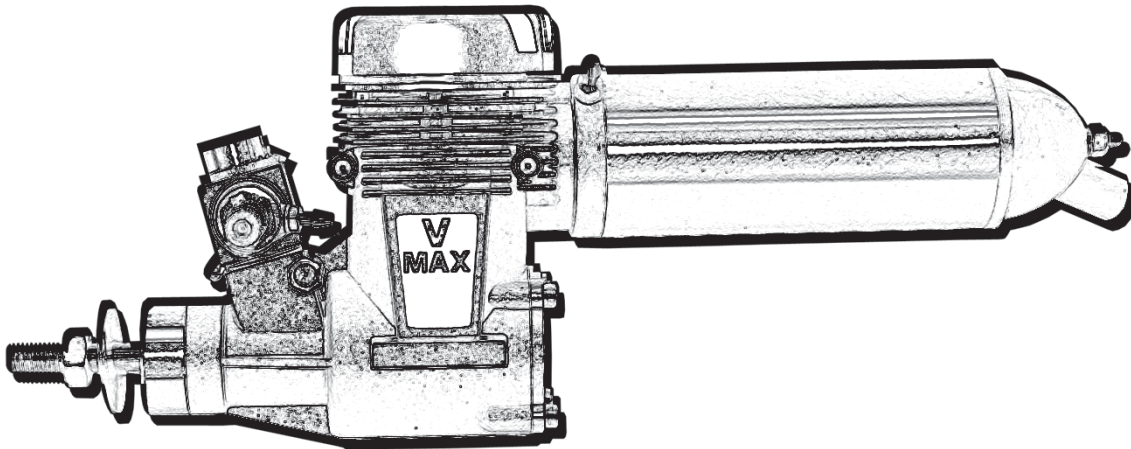

OWNERS MANUAL



LIABILITY DISCLAIMER

It is important that the following liability disclaimer be
READ BEFORE INSTALLING OR USING THIS PRODUCT

Model engines, model engine fuel, propellers, spinners and products such as this VMAX model engine can be hazardous if improperly installed or improperly used. Be cautious and follow all safety recommendations when using your VMAX model engine and any third party accessories. Keep hands, tools, clothing and all foreign objects well clear of engines when they are operating. Wear safety glasses when starting or operating this engine. Take particular care to safeguard and protect your eyes and fingers and the eyes and fingers of other persons who may be nearby. Use only a good quality propeller that has no cracks or flaws. Stay well clear of the propeller and stay clear of the plane of rotation defined by the propeller. Keep spectators and small children back at least 10 metres (33) feet at all times when operating the engine.

The manufacturer, distributor, retailer and/or other suppliers of this product expressly disclaim any warranties or representations, either expressed or implied, including but not limited to implied warranties of fitness for any purpose.

In no event will the manufacturer, distributor, retailer and/or other suppliers of this product have any obligation arising from contract or tort, or for loss of revenue or profit, or for indirect, special, incidental, consequential or other damages arising from the use of this product.

In purchasing and/or using this product, the user accepts all responsibility for its use and accepts all liability associated with such use.

Proceeding with Installation and/or Use of this product indicates Agreement With and Acceptance of the Liability Disclaimer.

CAUTION

A model engine is not a toy. A model engine functions much like a full size engine. If you do not install and operate this product properly you can cause injury to yourself and others and damage property.
DO NOT INSTALL OR USE this engine if you are not qualified.

You are solely responsible for the mechanical and operational integrity of this engine and the way in which it is installed and used. Check all aspects of the installation, the engine, propeller, spinner and all other accessories attached or associated with this engine before and after each use.
Do not operate the engine unless you are sure that it can be operated safely.

1. WHAT YOU WILL NEED TO OPERATE THIS ENGINE

To start your engine, you will need the following tools and accessories.

- Glow fuel
- Fuel pump
- Fuel tubing
- Glow plug
- Glow plug wrench
- Glow plug battery with cord and clip, or
- Glow plug ignitor with built in battery
- Propeller
- Propeller wrench
- Chicken Stick, or
- Electric Starter with battery.

**FUEL IS
HAZARDOUS.**
Read Cautions
on Container

Ask about the VMAR
Engine Test Stand
#VMA-ETS120

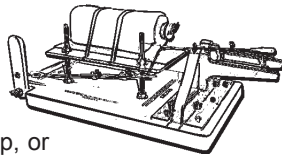

Particular attention should be paid to the following.

1.1) Glow fuel: Use only good commercial glow fuel containing zero to ten percent nitro methane and 18-20% oil content being a blend of castor oil and synthetic oil or all castor oil. Do not operate this engine on home made fuel or with fuel having less than 18% oil content or with fuel having synthetic oil only.

1.2) Glow plug: Use a medium to hot R/C long glow plug.

1.3) Propeller: Wooden propellers are preferred. If a spinner is used, make sure the spinner is securely attached and that the edges of the spinner do not touch the propeller. Ensure the propeller and spinner are balanced. An unbalanced propeller or spinner can cause damage to your engine and make it very difficult to adjust the engine for reliable operation.

1.4) Glow plug battery or ignitor. Select a voltage (**usually 1.5** or 2.0 volts) and capacity to ensure that the glow plug you have selected will glow a bright orange for at least five minutes.

2. SAFETY FIRST AT ALL TIMES

Operating any model engine requires skill and continuous safety precautions and considerations. This engine and the model into which it is installed can develop a great deal of power and speed. This power and speed can seriously injure you and other people and do substantial damage to property. If you are a beginner, be sure to get training from someone who has experience in the safe installation and operation of model engines before you attempt to install or use this engine. Regardless of your experience level, we recommend having a third party double check your installation before operating this engine. **You are solely responsible for the mechanical and operational integrity of this engine and the way in which it is installed and used.**

3. SAFETY INSTRUCTIONS

3.1) Use safety glasses when starting and operating your engine.

3.2) Do not operate the engine near loose gravel, sand, small particles or other debris. The rotation of the engine and propeller can throw loose material into your face and eyes and injure spectators.

SAFETY INSTRUCTIONS continued

3.3) Do not allow loose clothing such as shirt sleeves, ties or scarves to come into contact with the engine, propeller, spinner, crankshaft or other rotating or moving items attached to the engine.

3.4) Remove all loose items from your shirt pockets, hat or elsewhere so that they do not fall into the area near the engine.

3.5) Make sure the glow plug ignitor, glow plug clip, glow plug cord, starter cord, fuel line and other objects are well clear of the propeller, spinner, crankshaft or other rotating or moving items attached to the engine.

3.6) If you use a spinner make sure that the edges of the spinner do not touch the propeller itself to prevent propeller failure and injury caused by flying propeller blades.

3.7) Read the WARNING LABELS on fuel containers. FUEL IS HAZARDOUS. Keep engine fuels in a safe place away from children, sparks, heat or anything that could ignite the fuel. Do not smoke near fuel or when fueling or operating your engine.

3.8) Operate your engine only in WELL VENTILATED AREAS. Do not operate your engine in a garage or other building. Model engine exhaust contains carbon monoxide. Carbon monoxide is toxic and should not be breathed.

3.9) Read the WARNING LABELS on propellers. Do not use a propeller that has any nicks, scratches, splits, cracks or any sign of wear or damage. Never alter or repair a propeller.

3.10) Use only a good quality propeller that has no cracks or flaws. Stay well clear of the propeller and stay clear of the plane of rotation defined by the propeller.

3.11) Keep hands, tools, clothing and all foreign objects well clear of engines when they are operating. Take particular care to safeguard and protect your eyes and fingers and the eyes and fingers of other persons who may be nearby.

3.12) Keep spectators and small children back at least 10 metres (33 feet) at all times when operating the engine.

3.13) Use a "chicken stick" or electric starter for cranking the engine.

3.14) Make all engine and carburetor adjustments while you are behind the engine. Do not attempt to reach over a rotating propeller or crankshaft.

3.15) Do not throw anything into a running engine to stop it. To stop the engine, cut off the air supply by closing the carburetor or cut off the fuel supply by pinching the fuel line leading to the carburetor.

3.16) Be particularly cautious when moving or carrying your model with the engine running. Make sure the propeller is well away from you and others.

3.17) Do not operate the engine near electric power lines, wires, antennas, highways or other hazardous areas.

3.18) Model engines become hot when running. Do not touch any part of the engine when hot.

4. BREAKING IN YOUR ENGINE.

THIS IS AN ABC ENGINE. IT WILL BE VERY TIGHT AT TOP DEAD CENTER. THIS IS NORMAL. AFTER THE FIRST FEW RUNS IT WILL LOOSEN UP SOMEWHAT BUT REMAIN TIGHTER AT THE TOP WHEN COLD THROUGH ITS LIFE.

Your VMAX engine requires minimal break in time. We strongly recommend the use of an engine test stand such as the VMAR #VMA-ETS120 for the first running and break in of your VMAX engine. You can do the first runs with your engine installed in a model but it is not recommended.

We recommend breaking in the engine by running it at a very rich setting for approximately 4 tanks of fuel. (32 oz)

4.1) Attach the muffler, muffler gasket & carburetor firmly to your engine and carefully install a glow plug with washer into the top of the engine and a suitable prop and spinner. See the prop selection guide on the back page. Make sure the propeller is firmly attached with the curved (usually printed as well) surface facing forward. Use a wrench to tighten the propeller nut & washer firmly.

4.2) Mount the engine on your test stand and connect the fuel lines. Make sure the tank is the right size & that the fuel tank horizontal center line is about 9mm (3/8") below the needle valve as illustrated on page 8. Fill the tank with good quality glow fuel. See Page 2 for oil and nitro recommendations.

4.3) See Figure 1 and install the high speed needle valve and turn the high speed needle valve (black knurled knob on the side opposite from the muffler) slowly clockwise until it seats and you begin to feel resistance. Then back the needle valve out about 2-3/4 turns.

4.4) Stop now and ensure that you are following all of the safety instructions.

4.5) With the throttle fully open (throttle arm fully forward), place your finger over the carb inlet. With your other hand turn the engine over several times counter-clockwise (as viewed from the front) until you see fuel flowing from the tank to the carburetor.

4.6) Connect the glow plug ignitor and reduce the throttle to about 1/4 open. "Prime" the engine by squirting a small amount (10 drops or so) of fuel into the carburetor inlet.

4.7) Using an electric starter or chicken stick start the engine in a counter-clockwise direction (as viewed from the front). Never use your fingers to start the engine.

4.8) When the engine fires make sure the engine is pushing air back away from the rear of the engine. If not, remove the glow plug ignitor and firmly pinch the fuel line running to the carburetor to stop the engine.

4.9) With the engine rotating counter-clockwise and pushing air back away from the rear of the engine, leave the glow plug ignitor in place. Advance the throttle to full and back out the needle valve a bit more to ensure that the engine is running at full throttle but gurgling and spewing lots of oil and fuel out of the exhaust. This very rich running is essential for a smooth trouble free break in.

4.10) Let the engine run for a minute or so and then stop it by removing the glow plug heat and pinching the fuel line connected to the carburetor.

BREAKING IN YOUR ENGINE continued

4.11) When the engine has cooled for 5 minutes or so, start it again and turn the needle valve in 2-3 clicks to lean out the mixture slightly. The engine will run a bit more smoothly and without as much excess fuel and oil coming out of the muffler. Try to remove the glow plug ignitor and see if the engine will continue to run on its own.

4.12) Repeat this process several times on the first tank, each time running slightly longer and slightly leaner but never running screaming fast and always with a gurgling sound and a sloppy exhaust residue. Always let the engine cool between runs.

4.13) Now fill up the tank and run the engine again without leaning it out any more. Leave the needle valve rich with a gurgling sloppy sound for now. Run for 2-3 minutes at a time at first then gradually increase the run times to about 5 minutes each as you burn up 3-4 tanks of fuel.

4.14) After you have broken in the engine with 3-4 tanks of fuel, set the idle stop screw so that the carb can just about but not quite close. Loosen the idle stop screw, put a straight pin in the carb barrel and rotate the barrel gently closed as far as the pin will allow, then tighten the idle stop screw into position. Do not adjust the low speed mixture at this time.

FIGURE 1 - CARBURETOR

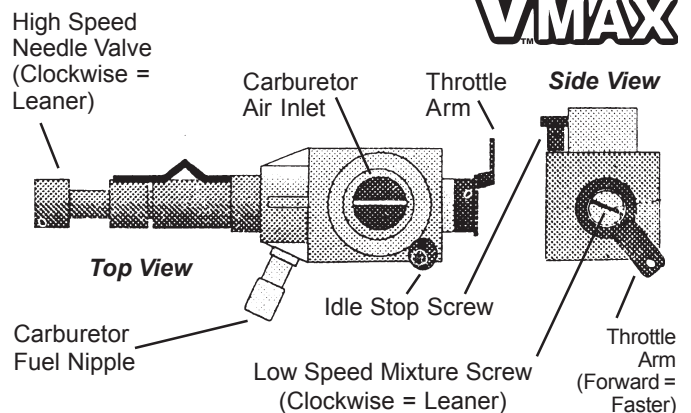

5. INSTALLING THE ENGINE INTO YOUR MODEL

5.1) Check that all bolts on your engine are tight using the allen wrench supplied. Do not overtighten or you will strip the bolt hole threads, just make sure that the bolts are firmly seated.

5.2) See your model instructions for information about fitting the engine into the model. Install the muffler and a prop with spinner onto the engine and loosely fit the engine into the model. Confirm clearances around the muffler, carburetor inlet, throttle arm, needle valve, glow plug and propeller with spinner. Confirm that fuel lines can run from the fuel tank to the carburetor and muffler pressure nipple without kinking.

5.3) Ensure that the horizontal center line of the fuel tank is approximately 9mm (3/8 inch) below the needle valve. See the illustration on page 8.

5.4) Depending on the mounting system provided with your model, firmly mount the engine into your model.

5.5) Connect the appropriate fuel lines to the engine carburetor and muffler pressure nipple. Do not get them mixed up.

6. OPERATING THE ENGINE IN YOUR MODEL

6.1) Ensure that you follow all of the safety instructions when operating your engine.



6.2) Always remove the fuel lines from the muffler and carburetor and fill up the fuel tank via the fuel feed line that was running to the carburetor. When the tank is full, re-install the fuel lines. Do not fuel up with the muffler pressure line connected to the muffler.

6.3) Turn the high speed needle valve (black knurled knob on the side opposite from the muffler) slowly clockwise until it seats and you begin to feel resistance. Then back the needle valve out about 2-1/4 turns. (See Figure 1)

6.4) Do not connect your glow plug ignitor yet. With the throttle fully open (throttle arm fully forward), place your finger over the carburetor air inlet. With your other hand turn the engine over several times counter-clockwise (as viewed from the front) until you see fuel flowing from the tank to the carburetor. Make sure you always hand crank your engine before using an electric starter or chicken stick.

6.5) Now connect the glow plug ignitor and reduce the throttle to about 1/4 open. "Prime" the engine by squirting a small amount (10 drops or so) of fuel into the carburetor inlet.

6.6) Using an electric starter or chicken stick start the engine in a counter-clockwise direction (as viewed from the front). Never use your fingers to start the engine.

6.7) When the engine is running, remove the glow plug ignitor and open the throttle fully. Hold the nose of the aircraft straight up and slowly turn the high speed needle valve clockwise in steps of about 1/8 of a turn. Listen carefully as the engine RPM increases. When you get to the point that the engine RPM is near its peak, back the needle valve off counter-clockwise about 1/8-1/4 of a turn and lower the nose of the aircraft to level. At full throttle with a full tank and a level attitude the engine should be running with a slightly rich gurgle. As you lift the nose of the aircraft, the engine should lean out slightly. If in doubt always err on the side of being a bit too rich when the tank is full and the nose is held high.

6.8) Adjust the low speed idle stop screw and your servo throws so that at normal mid trim position on your throttle the engine is running just above the point where it stops. Ensure that the engine will stop when you pull back on the throttle trim or when you hit your "kill throttle" button if your radio offers this feature.

6.9) We suggest adjusting the low speed mixture only if necessary and only after the engine is well broken in. Trying to adjust the low speed mixture on a new engine that has not been broken in will be very frustrating and generally does more harm than good.

6.10) The low speed mixture screw is a small brass screw recessed into the center face of the throttle arm. It influences idle reliability & the smoothness of transition to higher speeds. After your engine is broken in, the best way to check and set the low speed mixture is to warm the engine up for 5 minutes or so at full throttle and then reduce the RPM to idle, wait 30 seconds and then pinch the fuel line to cut off fuel flowing to the carburetor.

- If the engine speeds up slightly before quitting, the low speed mixture is about right and should not be adjusted,

- If the engine quits without speeding up slightly, the low speed mixture is a bit too lean... richen the low speed mixture by backing the low speed mixture screw out counter-clockwise about 1/8 of a turn.

- If the engine speeds up considerably before quitting, the low speed mixture is too rich, lean out the mixture by turning the low speed mixture screw in clockwise about 1/8 of a turn.

7. CARE AND MAINTENANCE OF YOUR ENGINE

7.1) Please read over the section entitled "THINGS YOU SHOULD NOT DO".

7.2) Do not run your engine in dirty, dusty conditions.

7.3) Use clean filtered commercial fuel. Install a fuel filter on your pump to filter fuel as it goes into your fuel tank.

7.4) After each flying session

- run the engine dry by pinching the fuel line feeding the carburetor and let the engine run out of fuel. Pump out your fuel tank then re-connect all fuel lines.

- remove the glow plug and carefully put 6-10 drops of afterrun oil (Pacer After Run recommended) into the combustion chamber and another 6-10 drops into the carburetor inlet. Turn the engine over by hand 10 times. Reinstall the glow plug, close the carb and insert a small plug of wadded paper towel into the carburetor intake.



- use a stiff tooth brush and Fantastic or other non-abrasive household cleaner (dish soap and water will work) and clean all surfaces of the engine paying particular attention to thoroughly clean the head and all cooling fins.

7.5) Make sure your propeller and spinner are clean and balanced at all times. Discard your propeller if you find any cracks, splits or nicks.

7.6) Make sure your fuel container is firmly closed.

8. THINGS YOU SHOULD NOT DO!

Your VMAX engine will last a long time if you take care of it. On the other hand you can ruin an engine pretty easily if you ignore the following

8.1) DO NOT... run the engine in dusty dirty conditions.

8.2) DO NOT... run your engine after a crash without clearing dirt, grit and other debris from the engine.

8.3) DO NOT... use low grade home brew fuel.

8.4) DO NOT... use fuel with less than 18% oil content

8.5) DO NOT... use fuel with only synthetic oil in it. Make sure your fuel has all castor oil or a blend of castor and synthetic oil.

8.6) DO NOT... forget to break in the engine carefully, preferably on an engine test stand like the VMAR #VMA-ETS120

8.7) DO NOT... push the engine too hard, too fast, too lean or too hot. If you see oil residue literally burning onto the sides of the head to form a brown varnish... you are running too hot. If the hear the engine "sag off" at high RPM you are running the engine too lean and it is overheating.

8.8) DO NOT... fuel up with the fuel line attached to the muffler. You run the risk of flooding the engine.

8.9) DO NOT... hit the engine with an electric starter without turning it over by hand first. If the engine is flooded and has a hydraulic lock and you hit it with an electric starter you will bend the wrist pin or connecting rod or blow a hole in the top of the piston. Pretty much the dumbest and sadly the longest standing most popular way to ruin an engine!

THINGS YOU SHOULD NOT DO continued

8.10) DO NOT... leave fuel in the engine at the end of a flying session. Rust will start to form on the bearings also immediately! Run the engine dry of fuel by pinching the fuel line to the carburetor while the engine is running and keep the fuel line pinched until the engine stops for lack of fuel.

8.11) DO NOT... forget to use a good quality after run oil like Pacer After Run when you are finished for the day. After Run inhibits rust and keeps all the parts from gunking up with left over combustion oil.

8.12) DO NOT... continually adjust and muck around with the engine. Once you get it set up, only slight occasional adjustments are necessary to accommodate changes in ambient conditions like temperature and humidity. People with chronic "adjusticitis" usually adjust things until they don't work... then they call for an expert!

8.13) DO NOT... take your engine apart unless absolutely necessary. If you do take your engine apart it should only be because it is not working well. Usually you will not be able to do much aside from clean it out and/or replace worn parts. Note carefully how to reassemble it.

8.14) DO NOT... forget to clean the engine exterior after each flying session. Leaving oil and baked on residue on the exterior of the engine will reduce the cooling effectiveness of the head, fins and case and contribute to over overheating and premature wear.

8.15) DO NOT... use power tools or over tighten any of the bolts or you will strip the threads.

9. TROUBLESHOOTING



Your VMAX engine has been precision machined to give reliable and powerful performance with a minimum of break in and adjustment.

In the event that you have trouble getting your engine to start or operate smoothly please review the following troubleshooting tips.

9.1) DO NOT PANIC! Just about everything has a cause and an effect and with a bit of patience you can solve just about any problem.

9.2) READ THE INSTRUCTIONS. Even if you have read them once, read them again and fix anything you may have missed.

9.3) CHANGE ONLY ONE THING AT A TIME. Do not change 5 things at once, change one thing at a time and if the problem does not go away, revert back to the way you had it before the change.

9.4) MAKE SMALL CHANGES. Do not use a hammer and pipe wrench like you are doing home plumbing or working on a tractor. Use small hand tools and make slight careful adjustments. Do not overtighten any of the bolts or you can strip the threads and then you are in big trouble. After a small change, test the results before you change anything else. If the problem got worse, go back the other way on your adjustment.

9.5) CHECK THE SIMPLE THINGS FIRST. Your VMAX Engine is a precision made and elegantly simple piece of machinery. The simple things really do matter. Before you go off and start field stripping your carburetor check the following...

- make sure the carburetor is seated on the O-ring seal and firmly held into the engine by the retaining bolt.

- try a different glow plug and glow plug washer.

- make sure your glow plug ignitor makes the plug glow bright orange and that it can keep the plug glowing well for at least 5 minutes.

TROUBLESHOOTING continued

9.6) SOME MORE SIMPLE THINGS TO CHECK.

- make sure that your fuel is clean and good quality. Have a friend fly a tank of your fuel to make sure it performs well.

- check your fuel tank and tubing all the way from the muffler, back into the fuel tank and back through the cluck to the carburetor. No leaks, no kinks! Pull the pressure line from the muffler and try blowing in the muffler pressure line while pinching the carburetor fuel feed line... no leakage of fuel or air should occur. Now pull the fuel feed line from the carb and blow gently into the muffler pressure line... fuel should come out of the fuel feed line.

- turn the high speed needle valve in until it seats, counting the turns as you go for reference. Now back the needle valve out and remove it. Clean the end of the needle. With the fuel feed line connected to the carb, close the carburetor barrel, invert the engine and blow gently into the muffler pressure line and make sure that fuel flows into the carb fuel nipple and into the carb and out the needle valve receptacle. Blow gently and in short bursts to flush the carb without flooding it with fuel. Reinstall your needle valve as before and reconnect the pressure and fuel feed lines.

9.7) ASK A COMPETENT FRIEND FOR HELP. Check around at the flying field and you will notice that some people arrive at the field, set up their gear, do their checks, fuel up and fly fly fly with little in the way of grief or trouble. This is the kind of helper you want! Someone who knows their stuff and can help you sort out a problem carefully. Stay away from the verbose self-proclaimed "experts" who tend to spend all their time adjusting this and that but seldom get it in the air or when they do, seldom land with the engine still ticking over and the airplane in 1 piece!

9.8) USE AN ENGINE TEST STAND. When you have trouble with an engine in a model you can spend a lot of time trying to fix an engine problem only to find later that it is a fuel tank problem, vibration problem or other difficulty inherent with the model rather than the engine. A test bench really helps you set up an engine properly and you can change fuel tubing, fuel tank height, props, spinners, glow plugs etc much easier on a test stand.

10. VMAX WARRANTY

Your VMAX engine is warrantied to the original buyer to be free of manufacturing defects for a period of 1 year from date of purchase.

Problems caused by normal wear and tear, crash damage, abuse, improper use, failure to comply with the break in and operating instructions, customer disassembly, use of substandard fuel or damage caused by use of other accessories are not covered by this warranty.

All warranty returns MUST be accompanied by a dated sales receipt from an authorized VMAX re-seller and the original VMAX box. Warranty returns must be sent to the VMAX Service Center in your market area.

11. WHEN YOU NEED PARTS OR SERVICE.

11.1) Parts are available through your retailer or On-Line at www.richmondrc.com. Please see the parts list on page 7.

11.2) For repairs please remove the engine from your model and send the complete engine including muffler, carburetor and glow plug to the VMAX Service Center in your market area. Please visit www.richmondrc.com for the location of the Service Center in your market area.

11.3) Attach a short note explaining the difficulty you are having, fuel type used, glow plug used, propeller used etc. Be certain to include your name, address, day and evening phone numbers and your email address.

ENGINE EXPLODED 3-VIEW

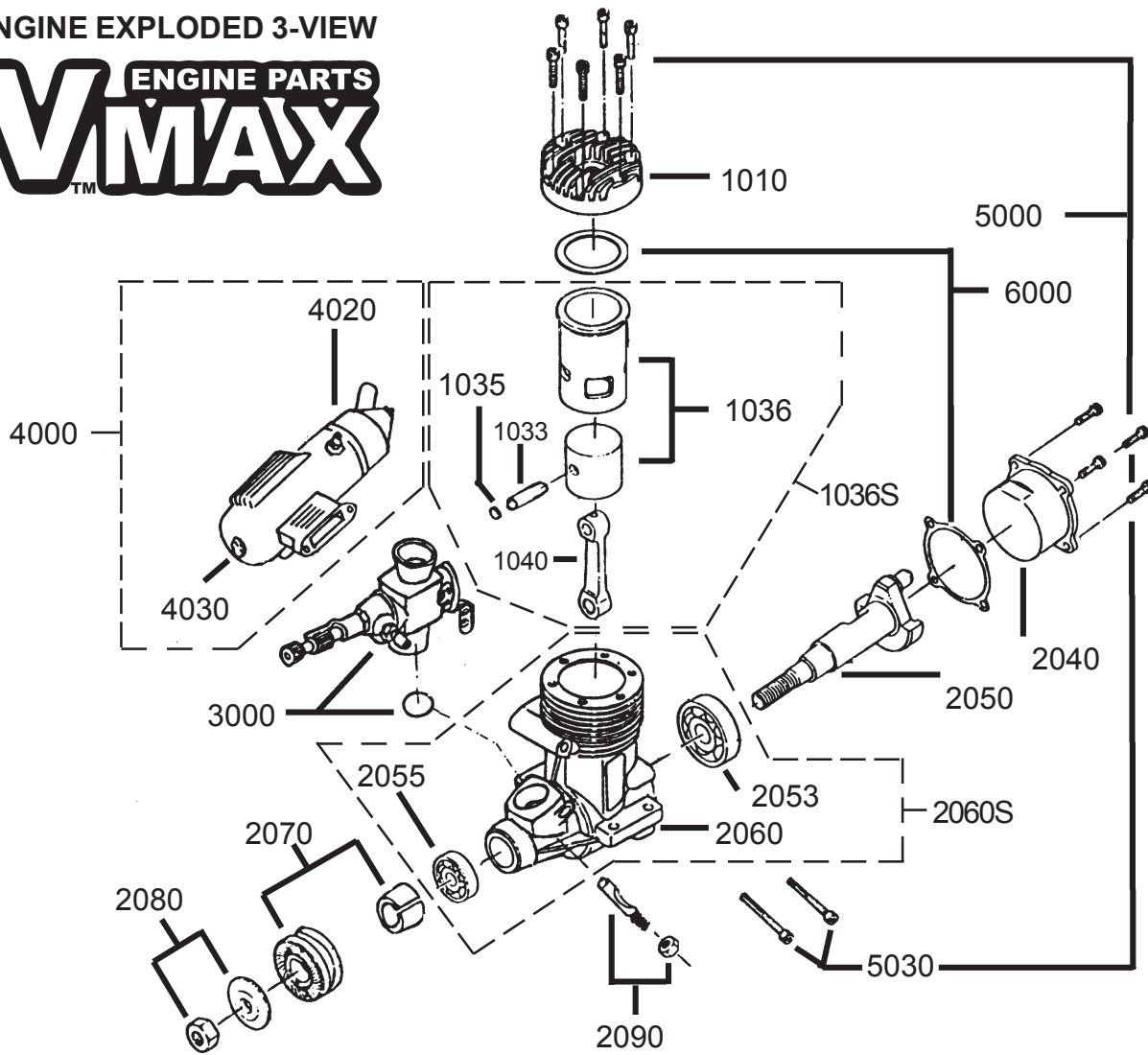
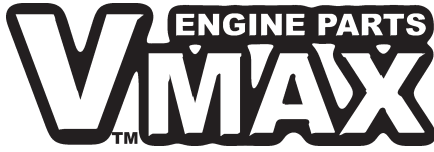

CARBURETOR EXPLODED 3-VIEW

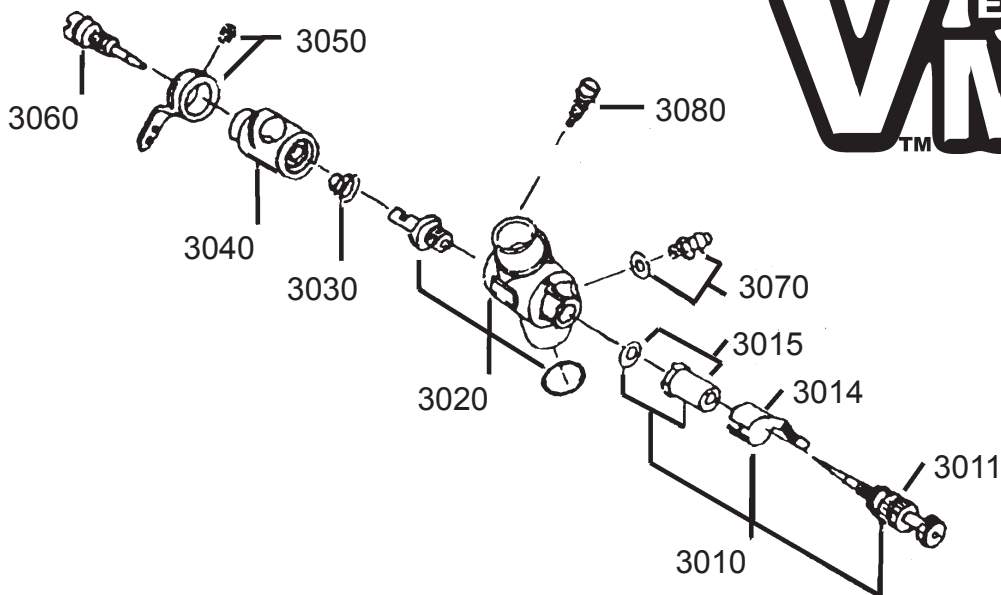
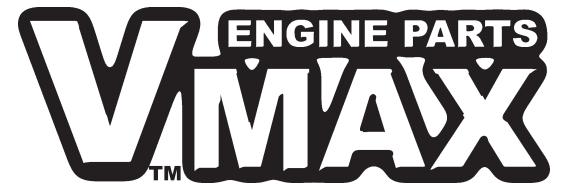

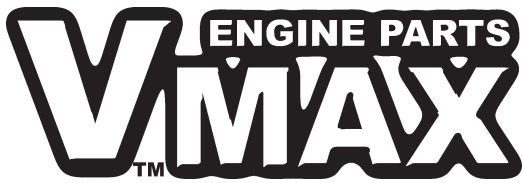

PARTS COMMON TO VMX-42PRO, 46PRO & 52PRO

- VXR-461010 CYLINDER HEAD - 46PRO [w/GASKET]
- VXR-461033 PISTON PIN - 46PRO
- VXR-461035 PISTON PIN RETAINER - 42PRO,46PRO,52PRO
- VXR-461036 CYLINDER & PISTON - 46PRO
- VXR-461036S CYLINDER, PISTON, CONROD & PIN SET - 46PRO
- VXR-461040 CONNECTING ROD - 42PRO,46PRO,52PRO
- VXR-462040 CRANKCASE COVER (BACKPLATE) - 42PRO,46PRO,52PRO
- VXR-462050 CRANKSHAFT - 42PRO,46PRO,52PRO - 1/4x28 NF THREAD
- VXR-462053 BEARING REAR ONLY FOR CRANKSHFT 42PRO,46PRO,52PRO
- VXR-462055 BEARING FRONT ONLY FOR CRANKSHFT 42PRO,46PRO,52PRO
- VXR-462060 CRANKCASE - 46PRO
- VXR-462060S CRANKCASE WITH BEARINGS - 46PRO
- VXR-462070 DRIVE WASHER & CONE - 42PRO,46PRO,52PRO
- VXR-462080 PROP WASHER & NUT - 42PRO,46PRO,52PRO
- VXR-462090 CARB RETAINER BOLT & NUT - 42PRO,46PRO,52PRO
- VXR-463000 CARBURETOR COMPLETE (w/NVALVE) - 42PRO,46PRO,52PRO
- VXR-463010 NEEDLE VALVE SET - 42PRO,46PRO,52PRO
- VXR-463011 NEEDLE VALVE ONLY - 42PRO,46PRO,52PRO
- VXR-463014 NEEDLE VALVE RATCHET SPRING - 42PRO,46PRO,52PRO
- VXR-463015 NEEDLE VALVE HOLDER & GASKET - 42PRO,46PRO,52PRO
- VXR-463020 CARBURETOR BODY & SPRAY BAR - 42PRO,46PRO,52PRO
- VXR-463030 ROTOR SPRING - 42PRO,46PRO,52PRO
- VXR-463040 CARBURETOR ROTOR - 42PRO,46PRO,52PRO
- VXR-463050 THROTTLE ARM (LEVER) - 42PRO,46PRO,52PRO
- VXR-463060 IDLE NEEDLE VALVE & O-RING - 42PRO,46PRO,52PRO
- VXR-463070 FUEL INLET NIPPLE & GASKET - 42PRO,46PRO,52PRO
- VXR-463080 THROTTLE STOP SCREW - 42PRO,46PRO,52PRO
- VXR-464000 MUFFLER - 42PRO,46PRO,52PRO
- VXR-464020 MUFFLER REAR PORTION ONLY - 42PRO,46PRO,52PRO
- VXR-464030 MUFFLER LONG SCREW & NUT - 42PRO,46PRO,52PRO
- VXR-465000 SCREW SET (x12 w/MUFFLER BOLTS) 42PRO,46PRO,52PRO
- VXR-465030 MUFFLER SCREWS (2) - 42PRO,46PRO,52PRO
- VXR-466000 GASKET SET (HEAD & BACKPLATE) - 46PRO
- VXR-46400010 MUFFLER SPACER 10MM (25/64") FOR 42PRO,46PRO,52PRO

PARTS UNIQUE TO VMX-42PRO

- VXR-401010 CYLINDER HEAD - 42PRO [w/GASKET]
- VXR-401033 PISTON PIN - 42PRO
- VXR-401036 CYLINDER & PISTON - 42PRO
- VXR-401036S CYLINDER, PISTON, CONROD & PIN SET - 42PRO
- VXR-402060 CRANKCASE - 42PRO
- VXR-402060S CRANKCASE WITH BEARINGS - 42PRO
- VXR-406000 GASKET SET (HEAD & BACKPLATE) - 42PRO

PARTS UNIQUE TO VMX-52PRO

- VXR-521010 CYLINDER HEAD - 52PRO [w/GASKET]
- VXR-521033 PISTON PIN - 52PRO
- VXR-521036 CYLINDER & PISTON - 52PRO
- VXR-521036S CYLINDER, PISTON, CONROD & PIN SET - 52PRO
- VXR-522060 CRANKCASE - 52PRO
- VXR-522060S CRANKCASE WITH BEARINGS - 52PRO
- VXR-526000 GASKET SET (HEAD & BACKPLATE) - 52PRO

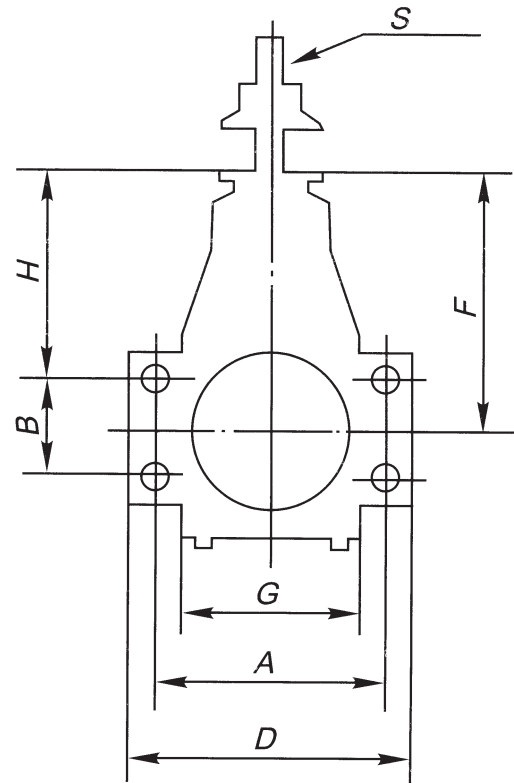

VMAX ENGINE DIMENSIONS 42PRO, 46PRO, 52PRO

	A	B	C	D	E	F	G	H	L	Wt	S=Shaft Thread
42PRO	44	17.5	84	51	88	60	35	51.3	70	TBA	1/4 x 28
46PRO	44	17.5	84	51	88	60	35	51.3	70	520	1/4 x 28
52PRO	44	17.5	84	51	88	60	35	51.3	70	TBA	1/4 x 28

Lengths shown in mm. (inches=mm/25.4) Wt shown in g (oz=g/28.4)

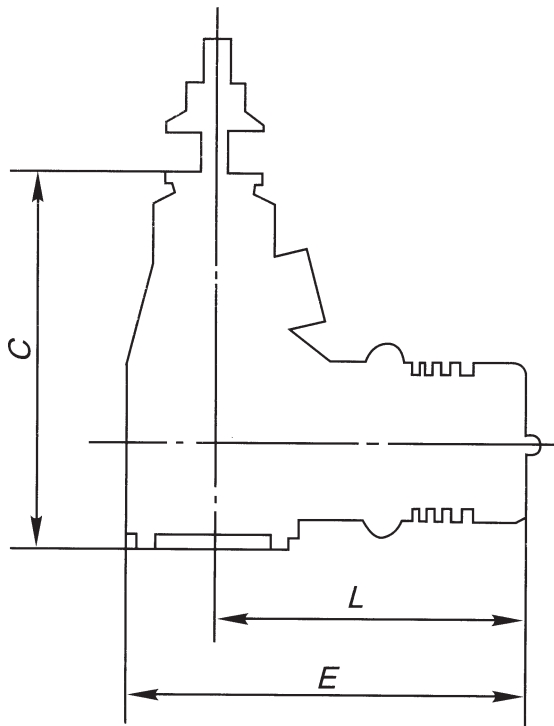

2 STROKE ENGINE PROPELLER SIZES (Diameter x Pitch in Inches)

ENGINE SIZE (cu in)	BREAK	
	IN	AFTER BREAK IN
.049	5 x 3	5.25 x 4, 5.5 x 4, 6 x 3 , 6 x 4, 7 x 3
.09	7 x 3	7 x 4 , 7 x 4.5, 7 x 5
.15	8 x 4	8 x 5 , 8 x 6, 9 x 4
.19-.25	9 x 4	8 x 5, 8 x 6 , 9 x 5, 9 x 6
.20-.30	9 x 5	9 x 6 , 9 x 7, 9.5 x 6, 10 x 5
.35-.36	10 x 4	9 x 6, 9 x 7 , 10 x 5, 11 x 4
.40	10 x 5	9 x 8, 10 x 6 , 11 x 5
.45-.47	10 x 7	10 x 6, 11 x 5, 11 x 6, 11 x 7 , 12 x 4
.50	11 x 6	10 x 8, 11 x 7 , 12 x 4, 12 x 5
.60-.61	11 x 7	11 x 7.5, 11 x 7.75, 11 x 8 , 12 x 6
.70	12 x 6	11 x 8, 12 x 8 , 13 x 6, 14 x 4
.78-.80	13 x 6	12 x 8 , 14 x 4, 14 x 5
.90-.91	14 x 6	13 x 8, 15 x 6 , 16 x 5
1.08	16 x 5	15 x 8 , 18 x 5
1.20	16 x 7	16 x 8 , 16 x 10, 18 x 5, 18 x 6
1.50	18 x 7	18 x 8 , 20 x 6
1.80	18 x 8	18 x 10, 20 x 6 , 20 x 8, 22 x 6
2.00	20 x 8	18 x 10, 20 x 6, 20 x 10 , 22 x 6

FUEL TANK SIZE

Recommended fuel tank size by engine displacement.

ENGINE	TANK
.10 cu in	60 cc (2 oz)
.19	120 cc (4 oz)
.25	120-180 cc (4-6 oz)
.29-.40	180-240 cc (6-8 oz)
.45-.50	240-300 cc (8-10 oz)
.60	360-420 cc (12-14 oz)
.76	420-480 cc (14-16 oz)
.90	480-600 cc (16-20 oz)
1.20	600-720 cc (20-24 oz)

Using too large a fuel tank can cause wide changes in RPM as the fuel is consumed, wide changes in RPM between inverted and upright flight, difficulties maintaining a consistent fuel flow in vertical maneuvers etc.

Using too small a fuel tank will reduce flight times.



VMAX is a Trademark of VMAR Manufacturing Inc. and authorized VMAX agents worldwide.
Copyright Richmond RC Supply Ltd 20020719. email: vmax@richmondrc.com
www.richmondrc.com

Please note that the best propeller size for your engine may vary considerably with altitude, air temperature, air humidity, fuel, nitro content and aircraft drag. Experienced flyers and your local hobby retailer may have suggestions for optimizing performance in your flying area.

As a general guideline, lower pitch results in more torque (vertical pull) while higher pitch results in more speed in level flight.

A crude method of comparing one propeller to another for level flight performance is to calculate the Power Factor as (2 x Diameter) + Pitch. The bigger the power factor the higher the performance the propeller... provided that the engine can handle the corresponding load. For example an 11 x 7 prop has a power factor of 29 while a 10 x 6 prop has a power factor of 26.

If your engine appears to be running overly hot and below peak RPM you should try a propeller with a lower power factor.

FUEL TANK POSITIONING

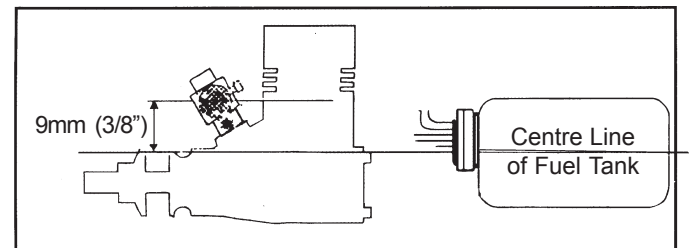

As the distance between the vertical position of the needle valve and the center line of the tank increases the following performance characteristics may be noted...

- more fluctuation in RPM between inverted and upright flight.
- more fluctuation in RPM between full tank and low tank due to mixture changes
- more of a need for muffler pressure to smooth out RPM fluctuations noted above.
- harder starting, more need for primer to start when engine is upright
- more of a tendency for flooding, fuel siphoning from tank into engine and hydraulic lock when engine is inverted.