

# CANADIAN MIST DEHAVILLAND BEAVER

Figure 14A

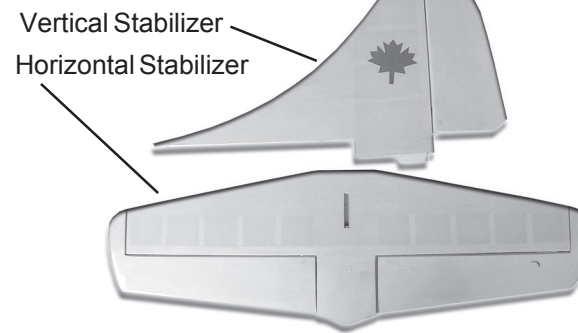

□Step 14: Locate the horizontal stabilizer. Slide the horizontal stabilizer into the receiving slot located at the rear of the fuselage. Center the stabilizer left to right. Look in the slot in the top of the fuselage and ensure the horizontal stabilizer slot appears centered.

Figure 14B

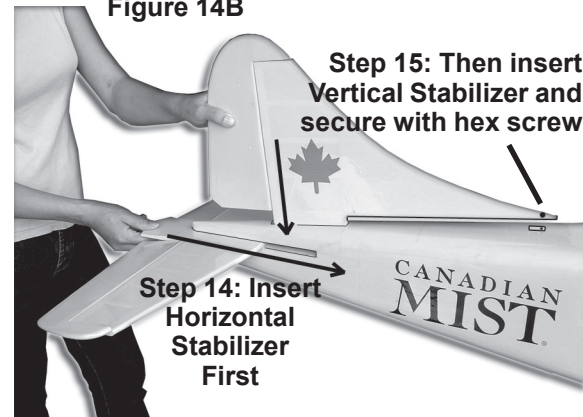

□Step 15: Locate the vertical stabilizer. Slide the vertical stabilizer into the receiving slot located in the top rear of the fuselage. Slide it down into the slot until well seated. Secure the vertical stabilizer into place using the small (2.5mm) allen wrench and one of the small hex head screws removed earlier.

□Step 16: Locate and install the two water rudders on the aft end of the floats. Secure the rudders into place with the retaining pins provided.

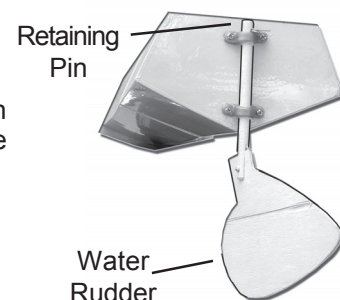

□Step 17: Locate and install the propeller/spinner assembly. The threaded bolt protruding from the back side of the spinner threads into the center of the dummy engine cowl plate. Ensure the prop is snugly threaded into place but do NOT overtighten.

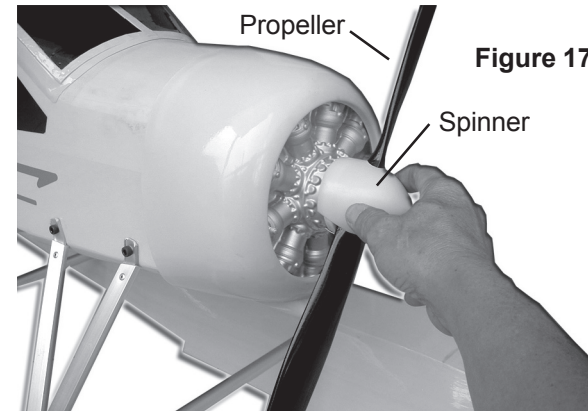

□Step 18: Carefully thread the hanging cable through the hole in the fuselage top hatch plate and reinstall the top hatch plate.

□Step 19: Carefully and slowly remove all assembly labels from the surface of the model. Do NOT remove by pulling the labels directly away from the surface to which they are applied. Pull the labels back on themselves parallel to the surface to which they are applied.

□Step 20: Cleaning and dusting: When using any cleaner or surface agent always test on a small out of the way surface first. Clean off any fingerprints with Fantastic or Windex. We recommend 50/50 Fantastic diluted with water. Avoid dousing any painted plastic parts, painted surfaces such as struts, windows or the cowl and engine. Apply light dusting of cleaner to towel to clean painted and plastic parts and wipe gently. For a higher gloss shine and to remove dust from this model use a light application of Armoral and buff with a soft cloth. Remember... always test any cleaner or surface agent on a small out of the way area first!

□Step 21: Choose a safe secure location to display the model. Avoid exposure to heat outlets, hot lights, strong air movements, swinging doors etc. Safety is important. Make sure the model is well clear of people and that it cannot be inadvertently knocked down or cause injury to anyone.

□Step 22: If hanging the model, a chain has been provided. The model will normally hang in a banked wing slightly nose down attitude. Safety is important. Check your installation and have someone else confirm that the model is securely displayed and that the model will not fall down or come in contact with people, heat or equipment.

# CANADIAN MIST DEHAVILLAND BEAVER

## SUMMARY OF ASSEMBLY STEPS

- Read Instructions
- Check Off Parts
- Attach Float Struts to Fuselage
- Attach Float Set
- Attach Wings
- Attach Tail Feathers (Stabilizers)
- Attach Water Rudders
- Attach Propeller
- Clean Up
- Hang or otherwise Display Safely.



## ... PLEASE READ THIS FIRST! ...

PLEASE REVIEW THIS DOCUMENT CAREFULLY INCLUDING THIS LIST OF "STAY OUT OF TROUBLE... MUST DO'S!"

1. READ ALL THE DOCUMENTATION before doing anything else.
2. DO NOT REMOVE ANY LABELS OR STICKERS until advised and note the correct procedure for doing so.
3. UNPACK CAREFULLY and RETAIN ALL PACKAGING until you are completely finished the assembly process.
4. ALLOW ENOUGH TIME to do a good job. The process is simple and can be completed in approximately 30 minutes.

5. DO NOT OVERTIGHTEN SCREWS, BOLTS AND FITTINGS! USE HAND TOOLS ONLY. Do NOT use power tools. Remember, making sure that things are snug and secure does not mean that you use an impact wrench and a hammer! GENTLE DOES IT! This is a model airplane not a concrete mixer!
6. REVIEW THE CLEANING INSTRUCTIONS and test any cleaner or surface agent on a small out of the way area first.

## CAUTION

THIS MODEL IS FOR DISPLAY ONLY! THIS MODEL IS NOT SUITABLE FOR FLIGHT.

### CAREFULLY FOLLOW ALL INSTRUCTIONS

Choose a safe secure location to display the model. Avoid exposure to heat outlets, hot lights, strong air movements, swinging doors etc. Safety is important. Make sure the model is well clear of people and that it cannot be inadvertently knocked down or cause injury to anyone.

If hanging the model, a chain has been provided. The model will normally hang in a banked wing slightly nose down attitude. Safety is important. Check your installation and have someone else confirm that the model is securely displayed and that the model will not fall down or come in contact with people, heat or equipment.

**FOR DISPLAY ONLY - DO NOT ATTEMPT TO FLY THIS MODEL**



# CANADIAN MIST DEHAVILLAND BEAVER

**PLEASE NOTE.** With regards to directional references, the terms Left, Right, Front, Back, Forward, Aft, Front, Rear, etc are all with respect to a pilot sitting in the cockpit of an airplane and looking ahead to the propeller.

**Step 1:** BEFORE doing anything, please review these instructions from beginning to end and then follow the step by step instructions as you go through the assembly process.

**Step 2:** Unpack the box. Carefully remove the packing material and components from the shipping box. Do NOT discard anything until you have completed the assembly process.

**Step 3:** Check off the Parts. See the parts list below.

**PLEASE NOTE:** Leave all labels and stickers that have been applied at the factory in place until you have completed the assembly. Do NOT remove any labels or stickers until advised to do so.

## Main Components

- 1 Instruction Sheet
- 1 Fuselage (Main Body) with Cowl and 13 black hex head screws (5 x 3mm & 8 x 5mm)
- 2 Wing Panels (Left & Right) with Wing Struts
- 1 Vertical Stabilizer (Tail Fin)
- 1 Horizontal Stabilizer (Smaller Wing)
- 1 Float Set pre-assembled (Pontoons) with 4 black hex head screws.
- 2 Styrofoam blocks with notches for use as a crutch support for the fuselage when installing the float set.
- Several large foam packing sheets

## In a Sub-Box approx 11x5x4"

- 4 Sets of Float Struts (used to attach the float set to the fuselage)
- 1 Chain for hanging the model (approx 6-7 ft)
- 2 Hooks for use with chain
- 2 Water Rudders (small yellow) & retaining pins
- 2 Allen (Hex) Wrench Keys (2.5 and 4 mm)

## In & attached to second Sub Box 17.5x3.3x2.5"

- 2 Aluminum Tube Wing Joiners (16 & 18 mm)
- 1 Propeller with Spinner & Bolt attached.

**Step 4:** Locate the fuselage (main body) and remove the black hex head screws (8 big and 5 small) using the allen wrenches provided. There are 5 screws on each side of the fuselage and 3 small screws on the top of the fuselage. **RETAIN** the screws.

Do NOT remove any screws from the cowl (nose)

**Figure 5A**  
Float Struts



**Step 5:** Locate and attach the four float struts onto the fuselage using 8 of the larger black hex head screws. Two struts go on each side of the fuselage. The ends of the struts are numbered to match with corresponding numbers on the fuselage. Install screws at locations 1,2, 3, 4,5,6,7 and 8. Leave the screws loosely inserted at this time. Do NOT tighten the screws. The struts should be able to move slightly.

**Figure 5B**

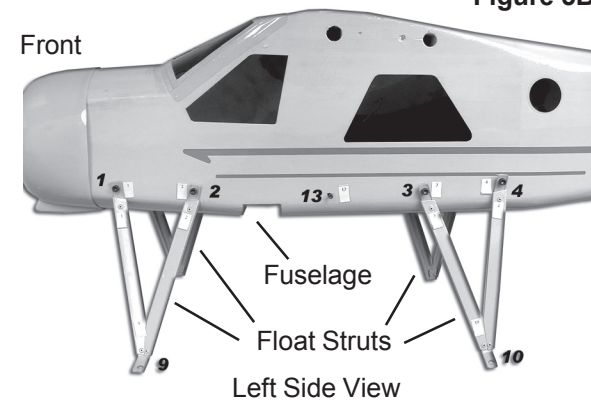

**Step 6:** Obtain one of the loose flat sheets of styrofoam that came in the shipping box and lay the foam sheet on a counter or table top that is at waist level.

**Step 7:** Locate and position the pre-assembled float set (pontoons) carefully on the foam sheet. Remove 4 black hex head screws from the floats

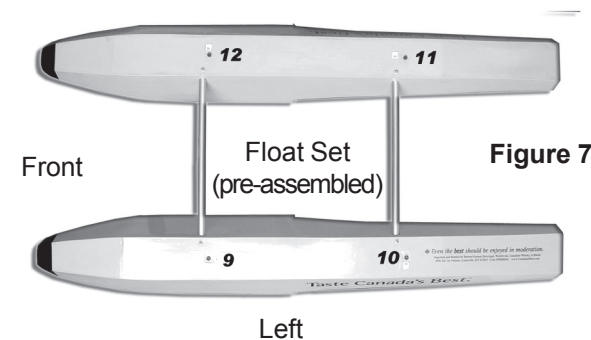

**Step 8:** Locate and position the two slotted foam blocks between the floats so that the tubes joining the floats slide down into the slots in the foam as shown in Figure 10A. The foam blocks can now be used as a crutch support for the fuselage during attachment of the fuselage to the floats.

**Step 9:** Carefully place the fuselage on to the foam blocks as shown in Figure 10A and align the float strut ends with the screw holes in the top of the floats. Install screws at locations 9,10, 11 and 12. Leave the screws loosely inserted at this time. The components should be able to move slightly. Remove the slotted foam blocks.

# CANADIAN MIST DEHAVILLAND BEAVER

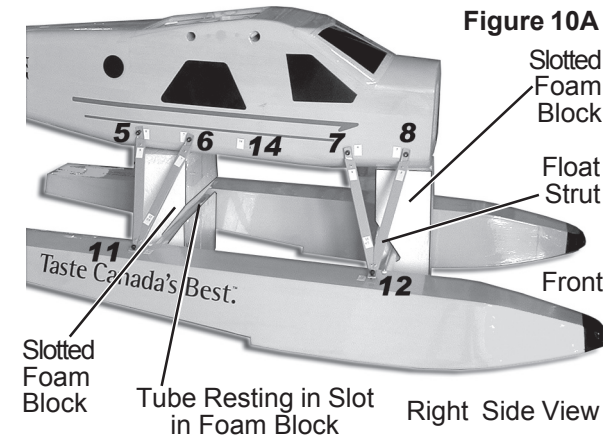

**Step 10:** Locate the larger (4mm) of the two allen keys. Allen keys look like a metal L. Using the allen key tighten the screws in two passes. The TWO pass approach ensures the parts align well.



**Step 10.1:** First Pass: LIGHTLY (leave just a touch of wiggle room) tighten the screws in this order...  
1, 3, 5, 7, 2,4,6,8 on the fuselage and 9,10,11,12 on the floats.

**Step 10.2:** Second Pass: Being careful to NOT overtighten any screws, secure the components so they do not move by snugly tightening the screws in the same order...  
1, 3, 5, 7, 2,4,6,8 on the fuselage and 9,11,10,12 on the floats.

**Step 11:** Remove the hatch from the top of the fuselage. Use the small allen wrench if you have not yet removed the two retaining screws.

**Step 12:** Locate the two aluminum wing joiner tubes and slide the tubes into the channels that pass through the fuselage. The larger tube (18mm) goes in the front channel, the smaller tube (16mm) goes in the rear channel. Center the tubes left to right.

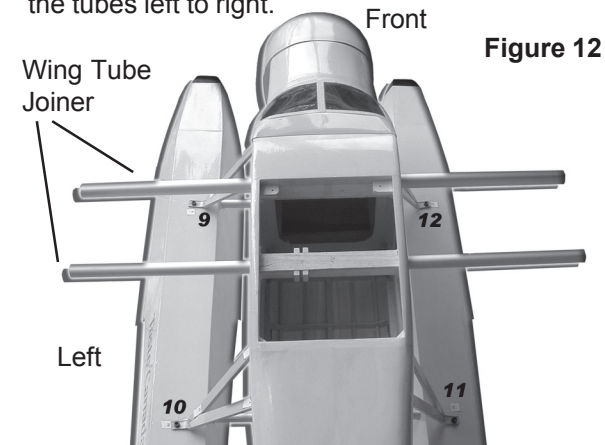

**Step 13:** Locate and examine the two wing halves. Locate and remove the butterfly nut and washers from each wing root. **Figure 13A**

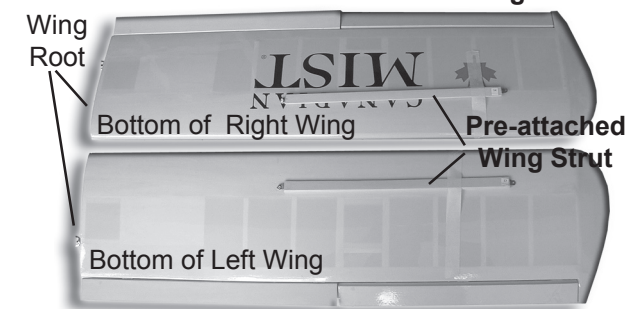

**Step 13.1** Free up the wing struts that have been pre-attached to the bottom of each wing. Let the wing struts hang loosely for now.

**Step 13.2** While securely holding the wing joiner tubes centered across the fuselage, carefully slide the left wing half on to the aluminum wing joiner tubes until the wing root (wood end of wing) contacts the fuselage.

**Step 13.3** Install the washer and butterfly nut onto the wing bolt from inside the fuselage. Tighten snugly but NOT overtightly.

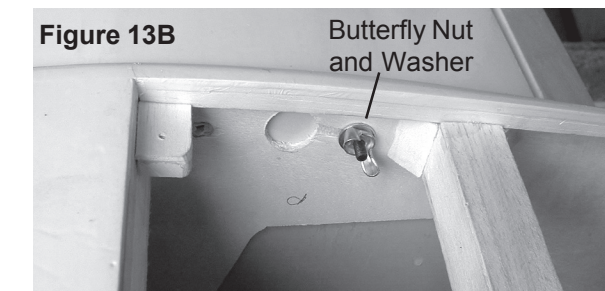

**Step 13.4** Attach the loose end of the wing strut to the side of the fuselage using the small (2.5mm) allen wrench and one of the small hex head screws removed earlier. Note the numbered indicator labels.

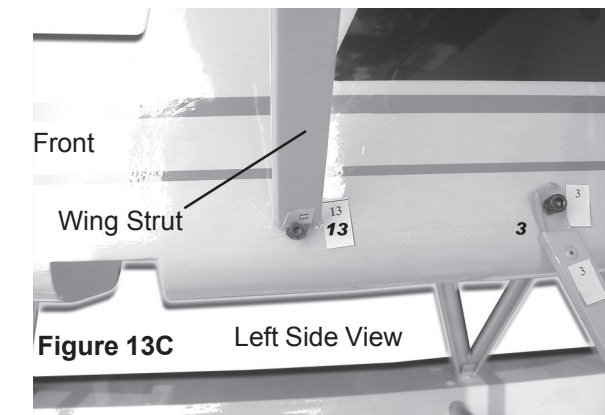

**Step 13.5** Carefully repeat steps 13.2, 13.3 and 13.4 for the right wing half.